

01		Änderungen		25.06.2024	depo
Index				Datum	Name
DEHOUST		ISO Methode E	 Schutzvermerk nach DIN ISO 16016 beachten Allgemeintoleranzen nach DIN 28005-1	Werkstoff	Maßstab 1 : 75
		Grauwasseranlage/Greywater System		Behälter-Nr.:	Gewicht 0,0 kg
Bearb.	Datum 05.07.2023	Name depo	DEHOUST GWtec® 440 B		
Gep.			Zeichnungs-Nr.:	Artikel-Nr.:	Blattgröße:
Norm.			D627640	813374	A4
				Blatt-Nr.: 1	Blattzahl: 3

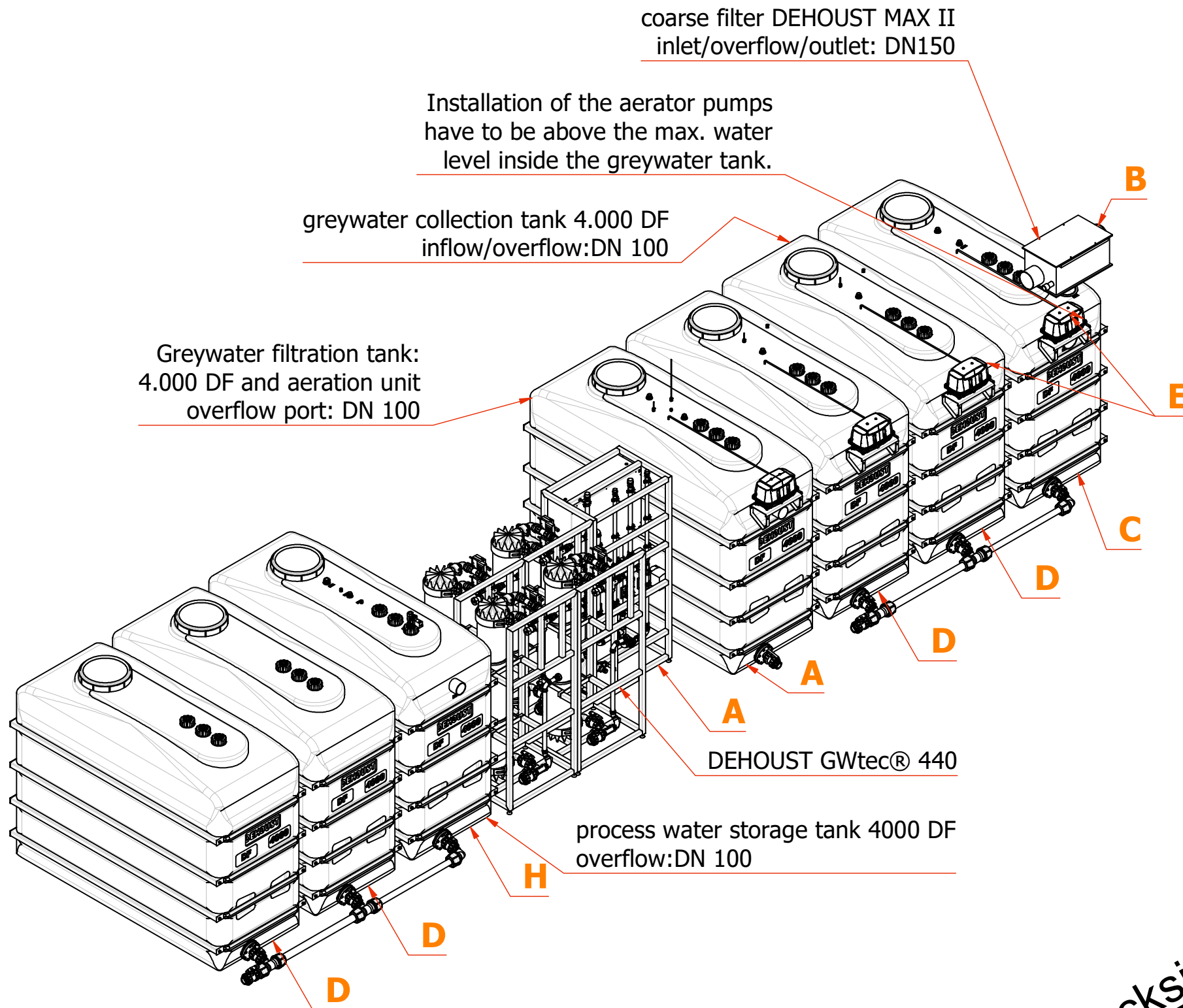

coarse filter DEHOUST MAX II
inlet/overflow/outlet: DN150

Installation of the aerator pumps
have to be above the max. water
level inside the greywater tank.

greywater collection tank 4.000 DF
inflow/overflow:DN 100

Greywater filtration tank:
4.000 DF and aeration unit
overflow port: DN 100

DEHOUST GWtec® 440

process water storage tank 4000 DF
overflow:DN 100

(A)
Type: DEHOUST GWtec® 440
Item: 813374
Max. treatment capacity: 15.000 litres/day
PVC flex hose:filtrate effluent 1" female thread, black, length 5m
weight: 260 kg

Greywater filtration tank: 1x PE HD 4.000 DF incl. aeration unit
overflow port: DN 100
drain valve:1 1/2" female thread
PVC flex hose:suction line 1" PVC flex hose blue, length 3 m
Empty weight: 120 kg

(B)
Type: coarse filter DEHOUST MAX II
Item: 812657
inlet/overflow/outlet: DN150
Connection backwash: 1" female; pmin: 1 bar; pmax: 2 bar
empty weight:15 kg

(C)
Type: greywater collection tank 4.000 litres
Item: 962059
inflow/overflow:DN 150
Drain valve:1 1/2" female thread
Empty weight: 235 kg

(D)
Type:Extension tank 4.000 L for a GW collection tank
or BW storage tank
item:962039
empty weight:235 kg

(E)
Type:Aeration unit for further PE HD greywater
collection tank
item:813440
PVC flex hose:3/4" female thread,red length 5m

(F)
Type: extension package aeration unit
Item: 813442
PVC flex hose:3/4" female thread,red length 5m

(G)
Type: greywater batch pump DOC 7
Item: 813444
PVC flex hose:1" female thread, black, length 5m

(H)
Type: process water storage tank 4.000 liters
Item: 962058
overflow:DN 100
Connection mains water back up: 1" female ; pmin: 1 bar; pmax: 10 bar
Emergency overflow DIN EN 1717:LxW 2 x 200 x 125 mm
Drain valve:1 1/2" female thread
Empty weight: 235 kg

Overall technical specification
Total weight:1.400 kg
electrical load:400 V / 16 A / 50 Hz / 3,35 kW

Backside

Pipes not included in delivery:

In- and overflow pipe DN 150
Pressure line backwash pump DN 32 (1 1/4") from tank H to DEHOUST GWtec® A
Pressure line booster pump DN 25 (1") from DEHOUST GWtec® to coarse filter DEHOUST II B

Installation of air compressor have to be above the max. water level
inside the greywater tank.

Dimensions in mm; distance to wall min. 300 mm.

*Height depends on the installation material

Technical change reserved. This installation example is subject to change.
All transactions are subject to our general terms and conditions.

01			25.06.2024	depo	
Index	Änderungen			Datum	Name
DEHOUST		ISO Methode E	Schutzvermerk nach DIN ISO 16016 beachten Allgemeintoleranzen nach DIN 28005-1		Werkstoff
		Grauwasseranlage/Greywater System		Behälter-Nr.:	Maßstab 1 : 40
		DEHOUST GWtec® 440 B			Gewicht 0,0 kg
Bearb.	Datum	Name	Zeichnungs-Nr.:	Artikel-Nr.:	Blattgröße:
	05.07.2023	depo	D627640	813374	A3
Gep.					Blatt-Nr.:
Norm.					2
					Blattzahl: 3

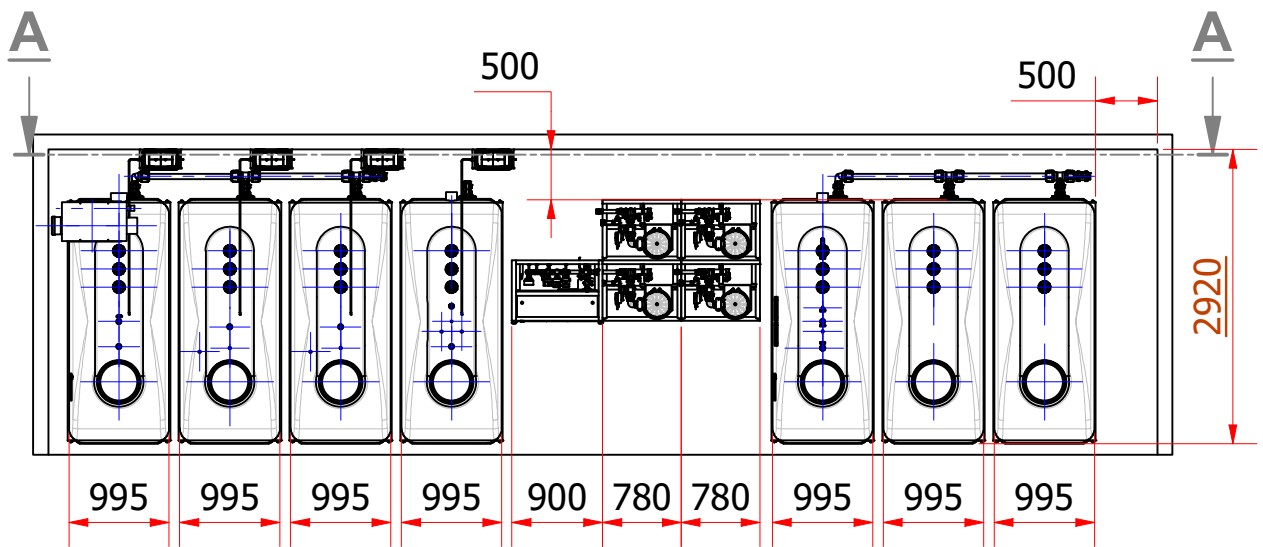
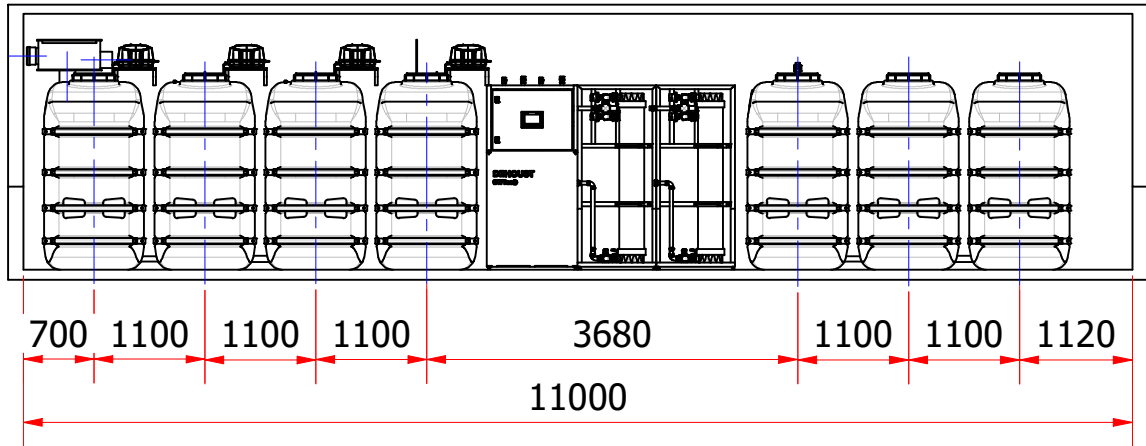

A-A

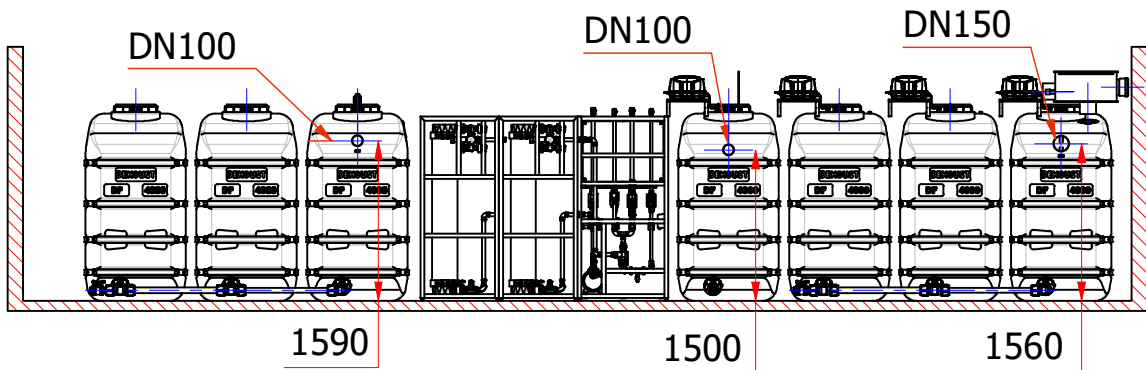

01				25.06.2024	depo
Index	Änderungen			Datum	Name
DEHOUST		ISO Methode E	Schutzvermerk nach DIN ISO 16016 beachten Allgemeintoleranzen nach DIN 28005-1		Werkstoff
		Grauwasseranlage/Greywater System		Behälter-Nr.:	Maßstab 1 : 75
Bearb.	Datum	Name	DEHOUST GWtec® 440 B		Gewicht 0,0 kg
Gep.	05.07.2023	depo	Zeichnungs-Nr.:	Artikel-Nr.:	Blattgröße: A4
Norm.			D627640	813374	Blatt-Nr.: 3 Blattzahl: 3