

**A-A ( 1 : 25 )**

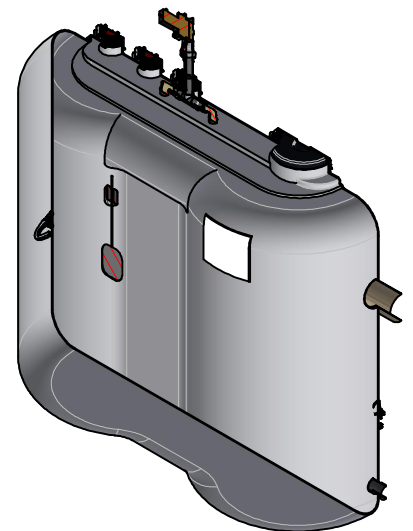
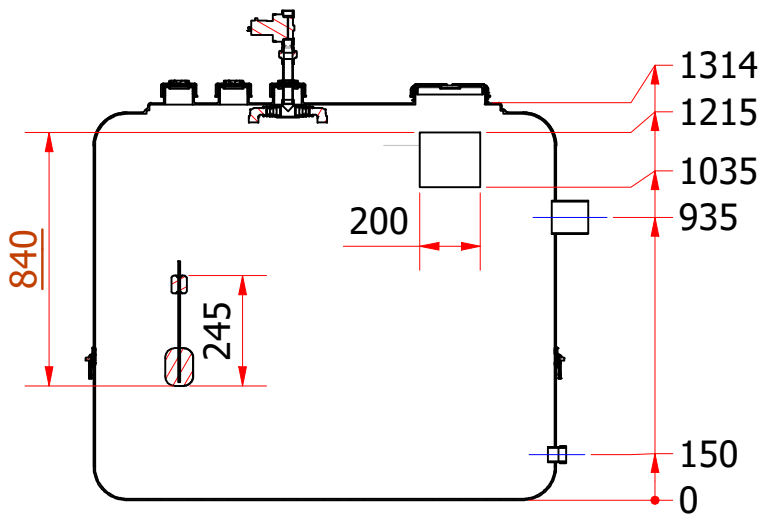

Index	Änderungen		Datum	Name
<b>DEHOUST</b>	ISO Methode E		Schutzvermerk nach DIN ISO 16016 beachten Allgemeintoleranzen nach DIN 28005-1	
	AQF 1100		Werkstoff	Maßstab 1 : 25
Bearb.	Datum	Name	Behälter-Nr.:	Gewicht 7,4 kg
Gep.	04.07.2023	sk	Blattgröße:	Blatt-Nr.: 1
Norm.			A4	Blattzahl: 1
	Zeichnungs-Nr.:	Artikel-Nr.:		
	<b>D627615</b>	<b>813160</b>		