



# DEHOUST

ENERGY. HEAT. WATER.

## Installation, Operation and Inspection Manual

### DEHOUST Rain Manager RM 3 CONNECT with connection kit Fully automatic central rainwater manager with system separator



NEW: WITH WIFI CONNECTION



NOW WITH FEEDER PUMP CONNECTION SET



**Manufacturer:**

DEHOUST GMBH  
Gutenbergstr. 5 -7  
D-69181 Leimen (Germany)

**Contact:**

Phone: +49 (0) 6224 9702-0  
Fax: + 49 (0) 6224 9702-70  
E-mail: [info@dehoust.de](mailto:info@dehoust.de)

**Website:**

[www.dehoust.com](http://www.dehoust.com)



## Contents

<b>1. Safety instructions</b>	<b>5</b>
1.1. General safety instructions	5
1.2. Cross-reference to other instructions	5
1.3. Symbols used in this manual	6
1.4. Safety regulations	6
1.5. Risks and hazards from non-compliance with the manual	7
1.6. Operator's duty of care	7
1.7. Safety instructions for maintenance, inspection and installation work	8
1.8. Duties of the operatives	8
<b>2. General information</b>	<b>9</b>
2.1. Warranty and liability	9
2.2. Statutory warranty obligation (extract)	9
<b>3. General description</b>	<b>10</b>
3.1. Functional description	11
3.2. Scope of delivery	12
3.3. Optional accessories	12
3.4. Construction	15
3.5. Dimensions	16
3.6. Intended use	18
3.7. Improper use	18
<b>4. Technical data</b>	<b>19</b>
4.1. Comparison between DEHOUST RM3 and RM5	19
4.2. Pump characteristics in comparison	20
<b>5. Handling and storage / installation</b>	<b>21</b>
5.1. Transport	21
5.2. Requirements for the place of installation	21
<b>6. Assembly</b>	<b>22</b>
6.1. Wall installation	22
6.2. Removing the housing front	23
6.3. Connection to water pipes	24
6.4. Electrical connections	31
6.5. WIFI connection	33
6.6. Registering the RM3	36



<b>7. Control of components</b>	<b>39</b>
7.1. RM3 Controller	39
7.2. KIT FLOW SWITCH	43
<b>8. Commissioning</b>	<b>44</b>
8.1. Basic conditions	44
8.2. Step 1: Filling in mains water	45
8.3. Step 2: Filling in service water	46
8.4. Step 3: Completion of commissioning	47
8.5. Documentation	48
<b>9. Maintenance</b>	<b>50</b>
9.1. Inspections	50
9.2. Maintenance	52
<b>10. Malfunction / fault detection</b>	<b>53</b>
10.1. Fault indications at the controller	54
10.2. Malfunctions of entire system	55
<b>11. Decommissioning</b>	<b>57</b>
<b>12. Final disposal</b>	<b>57</b>
<b>13. Declaration of Conformity</b>	<b>58</b>
<b>14. Appendix: List of abbreviations and technical terms</b>	<b>59</b>



## 1. Safety instructions



**Read this manual before installation and commissioning and keep the manual within reach at the place of installation of the *Rain Manager*.**

**This applies to the operative(s), technician(s), or operator(s).**

### 1.1. General safety instructions

This manual contains basic instructions to be followed during transport, handling, installation, commissioning, operation, maintenance, storage and final disposal. For service water use of the *Rain Manager*, observe the permissible data, operating and use conditions specified in the Technical Data Sheet (TDS) and in the manual.

- ▶ Never exceed the operational limit values mentioned in the documentation in terms of pressure, temperature, etc.
- ▶ Follow all safety and work instructions given in the present manual.
- ▶ Respect all instruction notices directly attached to the equipment and keep them in a perfectly readable condition. This is true for, e.g.:
  - ▶ safety instructions
  - ▶ identifiers of ports and connections
  - ▶ type label
- ▶ Installation and maintenance work shall always be performed by duly authorized specialist personnel using appropriate tools.
- ▶ Have the operator check the technical condition of *Rain Manager* at regular intervals.
- ▶ Observe the local safety and accident prevention regulations for the operation of *Rain Manager*.
- ▶ Observe the generally accepted rules of engineering when installing and operating the plant.
- ▶ Modifications to *Rain Manager* are not permitted and will void all and any warranty claims.
- ▶ The operator is responsible for meeting any additional applicable local regulations not mentioned in the manual.

### 1.2. Cross-reference to other instructions

For safe and smooth operation of the system, observe the manuals for external devices as well as the present installation and operation manual.



### 1.3. Symbols used in this manual



Passages marked with this symbol indicate **danger**.

Any failure to comply with the related precautions may cause death, serious injury or substantial damage to property.



Passages marked with this symbol give a **warning to exercise caution**.

Any failure to comply with the related precautions may cause minor bodily injury or damage to property.



Passages marked with this symbol provide technical **information and user guidance** on how to avoid damage to the system. This symbol is not a safety instruction.



Passages marked with this symbol indicate **servicing intervals** that need to be observed. Here: every six months



Passages marked with this symbol indicate **servicing intervals** that need to be observed. Here: annually



Passages marked with this symbol indicate **servicing intervals** that are variable based on usage and wear rate. Servicing, maintenance or repair will be as needed.

### 1.4. Safety regulations

The following safety regulations apply in addition to the safety instructions and intended use given in this manual:

- ▶ Accident prevention, safety and operating regulations
- ▶ Safety regulations for handling hazardous substances
- ▶ Applicable standards and laws including but not limited to the following technical standards:  
DIN EN 16941-2, DIN EN12056, DIN 1988, DIN 1986, DIN EN 1717, DIN EN 806
- ▶ Specific national standards and laws have priority



## 1.5. Risks and hazards from non-compliance with the manual

Failure to observe the instructions given in this manual will void any warranty and compensation claims. Non-compliance with the manual may, for example, result in the following hazards:

- ▶ danger to persons due to electrical, thermal, mechanical and chemical effects
- ▶ loss of key functions of the product
- ▶ failure of prescribed servicing and maintenance methods
- ▶ environmental hazards due to leaking hazardous substances

## 1.6. Operator's duty of care

*Rain Manager* was designed and built after appropriate risk assessment and careful selection of applicable harmonized standards and other technical specifications. The product complies with the state of the art and guarantees maximum safety. In practical operation, this level of safety can only be achieved if all necessary measures are taken.

It is part of the operator's duty of care to plan these measures and supervise their implementation. In particular, the operator must ensure that

- ▶ *Rain Manager* is used for its intended purpose only;
- ▶ *Rain Manager* is operated in a perfect and fully functional condition only;
- ▶ a full version of the manual in a readable condition is constantly kept within reach at the place of installation of *Rain Manager*;
- ▶ *Rain Manager* is installed, commissioned, serviced and maintained by duly qualified and authorized personnel only;
- ▶ such personnel are instructed at regular intervals in all relevant aspects of safety at work and environmental protection and have read and understood the manual and, more specifically, the safety instructions contained therein;
- ▶ safety and warning labels attached to *Rain Manager* are not removed and are maintained in a readable condition;
- ▶ a risk assessment (in the spirit of Section §5 of the Safety at Work Act) is made to determine the additional risks and exposures resulting from the specific local working conditions at the place of installation of *Rain Manager*;
- ▶ all additional safety and other instructions arising from the risk assessment are grouped together in an operating procedure (in the spirit of Section §6 of the Work Equipment Usage Ordinance);
- ▶ sewer discharge is sufficiently dimensioned.



## 1.7. Safety instructions for maintenance, inspection and installation work

- ▶ You are not allowed to change or modify the *Rain Manager* system, unless with the prior consent of the manufacturer.
- ▶ Never use any parts other than original parts or spare parts authorized by the manufacturer. The use of non-compliant parts can void liability claims for defects arising therefrom.
- ▶ The system must be switched off during all work on the equipment.
- ▶ Allow the pump body to cool down to ambient temperature before any maintenance, inspection or installation work.
- ▶ Drain and depressurize the pump body before any maintenance, inspection or installation work.
- ▶ It is imperative to always observe the inspection/maintenance procedure described in the manual.
- ▶ Reinstall or reactivate all safety guards and protective devices immediately after the work is done. Before restarting operation, follow the steps mentioned in the Commissioning section of the manual.
- ▶ Keep unauthorized persons (e.g. children) away from the system.

## 1.8. Duties of the operatives

The *Rain Manager* system shall be installed, commissioned, repaired, maintained and decommissioned only by persons specifically trained, briefed and authorized for this purpose. The operator can request training sessions from the manufacturer/supplier as needed. Training sessions for the system must always be supervised by specialist personnel. The operator shall maintain an operating procedure containing clear assignment of authorities for every member.

Moreover, particular qualifications are required for the following activities:

- ▶ work on electrical equipment – shall be carried out by qualified electricians only;
- ▶ installation, commissioning, servicing, maintenance and repair work – shall be carried out by qualified specialist personnel only.

Basic regulations on safety at work, occupational health and accident prevention shall be observed.



## 2. General information

The manual is part of the mentioned series and models. The manual describes their correct and safe use in all operational phases. The type label indicates the series and size, key operating data and serial number. To maintain warranty claims in the event of damage, report damages immediately to the authorized dealer by indicating the installation site and the series number of the plant.

### 2.1. Warranty and liability

The *Standard Terms and Conditions of Sale and Delivery* of DEHOUST GmbH apply. No warranty and liability claims can be accepted in case of personal injury or material damage attributable to any of the following causes:

- ▶ improper use of the *Rain Manager*;
- ▶ improper installation, commissioning, operation and maintenance of *Rain Manager*;
- ▶ failure to follow the instructions in the manual in terms of transport, handling, storage, installation, commissioning, operation, servicing and maintenance of *Rain Manager*;
- ▶ arbitrary structural modifications to *Rain Manager*;
- ▶ improper repairs;
- ▶ disaster events by impact of foreign bodies and force majeure.

### 2.2. Statutory warranty obligation (extract)

The statutory warranty obligation according to Section § 437 of the German Civil Code (BGB) applies.

Within the statutory warranty period, DEHOUST will at no charge remedy functional defects arising from manufacturing or material defects.

This applies to any defects or malfunctions occurring despite correct installation, proper operation and full compliance with the operating and installation manuals.



### 3. General description



The *Rain Manager* is a centralized fully automatic rainwater harvesting system using a self-priming pump that ensures service water supply from e.g. rainwater cisterns and an integrated service water tank at all times.

A pressure booster with automatic control is a key component for a properly working rainwater system. The *Rain Manager* combines a powerful pump, a flow switch optimized for rainwater use and a controller for fully automatic operation. When the rainwater cistern is empty, the *Rain Manager* will only draw as much mains water as is currently needed. In such case, the *Rain Manager* will separate the mains drinking water from Category 5<sup>1</sup> fluids as defined in DIN EN 1717 Type AB and will effectively prevent recontamination backflow to the water mains.

The mains water make-up unit uses a free outlet as defined in DIN EN 1717 thereby ensuring that the high statutory drinking water quality standards are met.

---

<sup>1</sup> Examples for Category 5 fluids include rainwater, process or service water from greywater reuse, well water, and also applications in the fields of agriculture, slaughterhouses, laboratory facilities, underground sprinkler irrigation systems.



### 3.1. Functional description

The *Rain Manager* operates as a centralized pressure booster for your rainwater distribution system. The *Rain Manager* can be used for automatic control of the collecting tanks (such as cistern, underground tank) by optimized increase in pressure. The *Rain Manager* checks and monitors the rainwater distribution system and identifies any faults or malfunctions autonomously. The rainwater distribution system remains operational even when the collecting tank is empty, as mains water is automatically supplied to the points of use via the *Rain Manager*.

---

Depending on the use case (such as drip irrigation in a garden), installing a separate membrane expansion vessel should be considered. Such a vessel will avoid a high switching rate (on/off cycling) of the booster pump.



Continuous cycling of the pump can cause failure of the flow switch first and then the pump will keep running without being switched off. If there is no water, the pump will be damaged beyond repair. In an early stage, also the pump's starting capacitor can be damaged.

The membrane expansion vessel must be suitable for service water operation. The upstream pressure in the membrane expansion vessel must be 0.3 to 0.5 bar below the cut-in pressure of the pump. Use an appropriate design program of the manufacturer for dimensioning the vessel.

---



## 3.2. Scope of delivery

*Rain Manager* ready-to-connect rainwater system comprising:

- ▶ RM3 controller (centralized electric control)
- ▶ DN 50 emergency overflow fitting on the service water tank
- ▶ Free outlet acc. to DIN EN 1717
- ▶ Type AB proportional mains water make-up valve
- ▶ 20 m float switch
- ▶ Motor-operated valve for water level adjustment
- ▶ Flow switch KIT including a pressure gauge
- ▶ No-maintenance corrosion-free multi-stage centrifugal pump
- ▶ 1.50 m long power cable
- ▶ Wall mounting kit including an anti-vibration mount
- ▶ Connection set for the flexible connection of water-carrying pipes
  - ▶ Reinforced hose for mains water connection
  - ▶ Reinforced hose and ball valve for service water connection
  - ▶ Flexible suction hose for rainwater intake
- ▶ Installation and Operation Manual

## 3.3. Optional accessories

### 3.3.1. "Mini" feeder pump system package



For covering larger intake losses between the *Rain Manager* and rainwater storage tank. Comprising:

- ▶ Mini-type immersion feeder pump
- ▶ 3 m long 1" hose with screw fittings
- ▶ Feeder controller for connection to *Rain Manager*
- ▶ Installation instructions

Article No. 814222



### 3.3.2. DEHOUST-SAFF Floating Intake



Flexible intake package for drawing cleanest water from the rainwater storage tank just below the water surface.

A larger suction strainer for lower frictional loss and thus reduced maintenance.

The delivery includes:

- ▶ a float unit with a fine filter
- ▶ a 1" check valve
- ▶ a 1" tank penetration fitting incl. gaskets
- ▶ a 1" flexible rubber spiral hose with internal anti-germ coating
- ▶ installation instruction

Art. No. 810540 with 2 m long hose

Art. No. 810543 with 3 m long hose

### 3.3.3. DEHOUST-TWIST Floating Intake

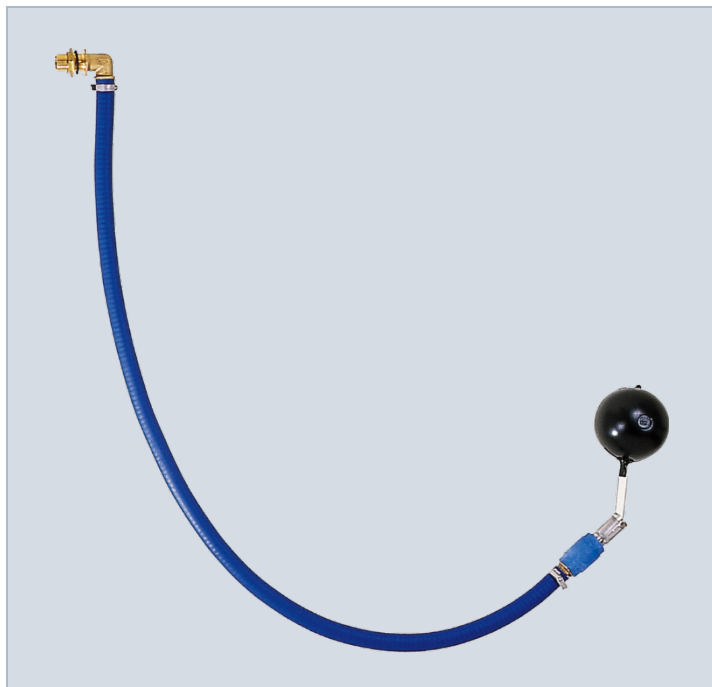

Flexible intake package for drawing cleanest water from the rainwater storage tank just below the water surface.

Suitable for rainwater already pre-filtered.

The delivery includes:

- ▶ a 1" flexible rubber spiral hose with internal anti-germ coating
- ▶ a float unit with a stainless steel strainer
- ▶ a 1" check valve
- ▶ a 1" tank penetration fitting incl. gaskets
- ▶ installation instruction

Art. No. 810541 with 2 m long hose

Art. No. 810542 with 3 m long hose



### 3.3.4. House Connection Kit



Kit for easier installation and connection of DEHOUST *Rain Managers* to the rainwater cistern.

The delivery includes:

- ▶ TWIST floating intake with 3 m long suction hose
- ▶ Conduit kit comprising a DN 100 seal (not suitable for pressurized water)
- ▶ PE sealing plug DN 100, 2 PE couplings of 1 inch internal thread for connecting the suction line and the control cables to the conduit and for sealing the house wall penetration.
- ▶ 15 m long PE tubing (DN 32 x 2.9)
- ▶ Kit of warning labels (1 sticker with symbol "No drinking water"; 25 stickers "No drinking water"; 2 stickers "This toilet is operated using service water"; 1 label "Attention! A service water recycling system is installed in this building. Interconnections prohibited"; 2 labels "Service water – not suitable for drinking")
- ▶ installation instruction

Article No. 812319

### 3.3.5. RM CONNECT Water Level Meter



Level meter for external service water storage tanks (e.g., rainwater cisterns).

Included in delivery:

- ▶ Submersible pressure sensor for water depths of 1-6 m
- ▶ Signal 4-20 mA
- ▶ 25 m connection cable
- ▶ Adapter plug
- ▶ installation instruction

Article No. 815300



## 3.4. Construction

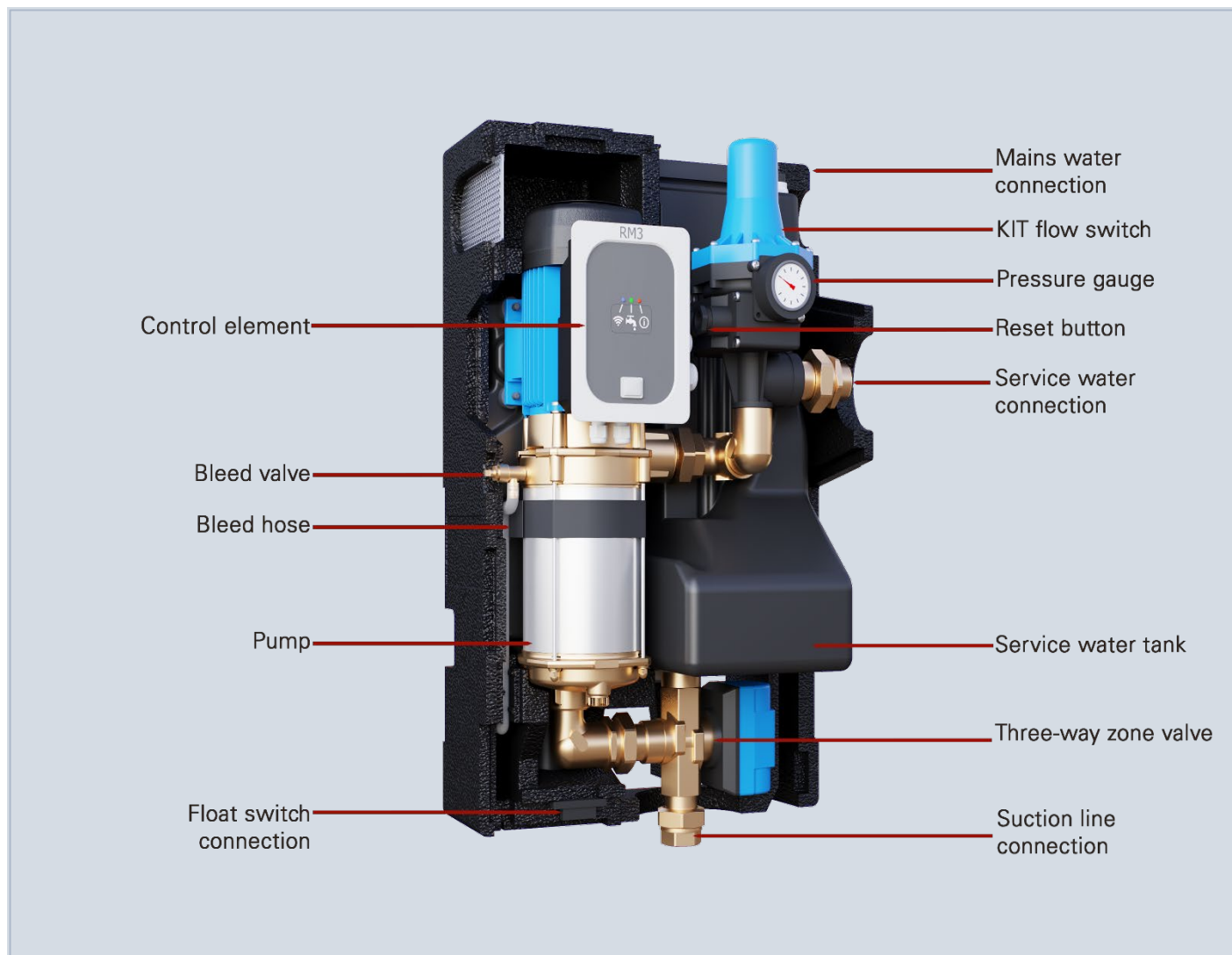

Figure 1: Rain Manager RM3 / description of components (key to symbols)



### 3.5. Dimensions

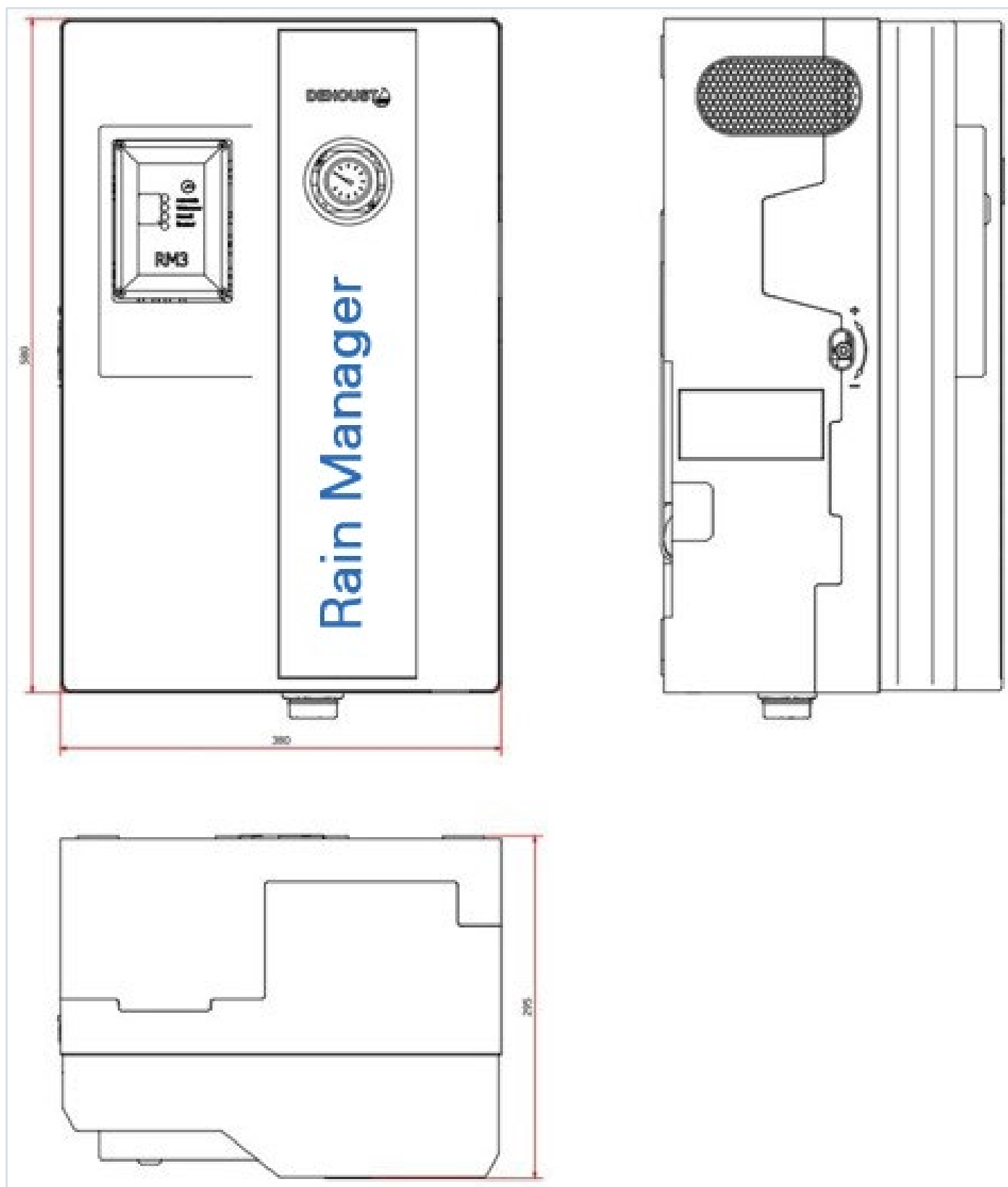

Figure 2: Overall dimensions (schematic view)

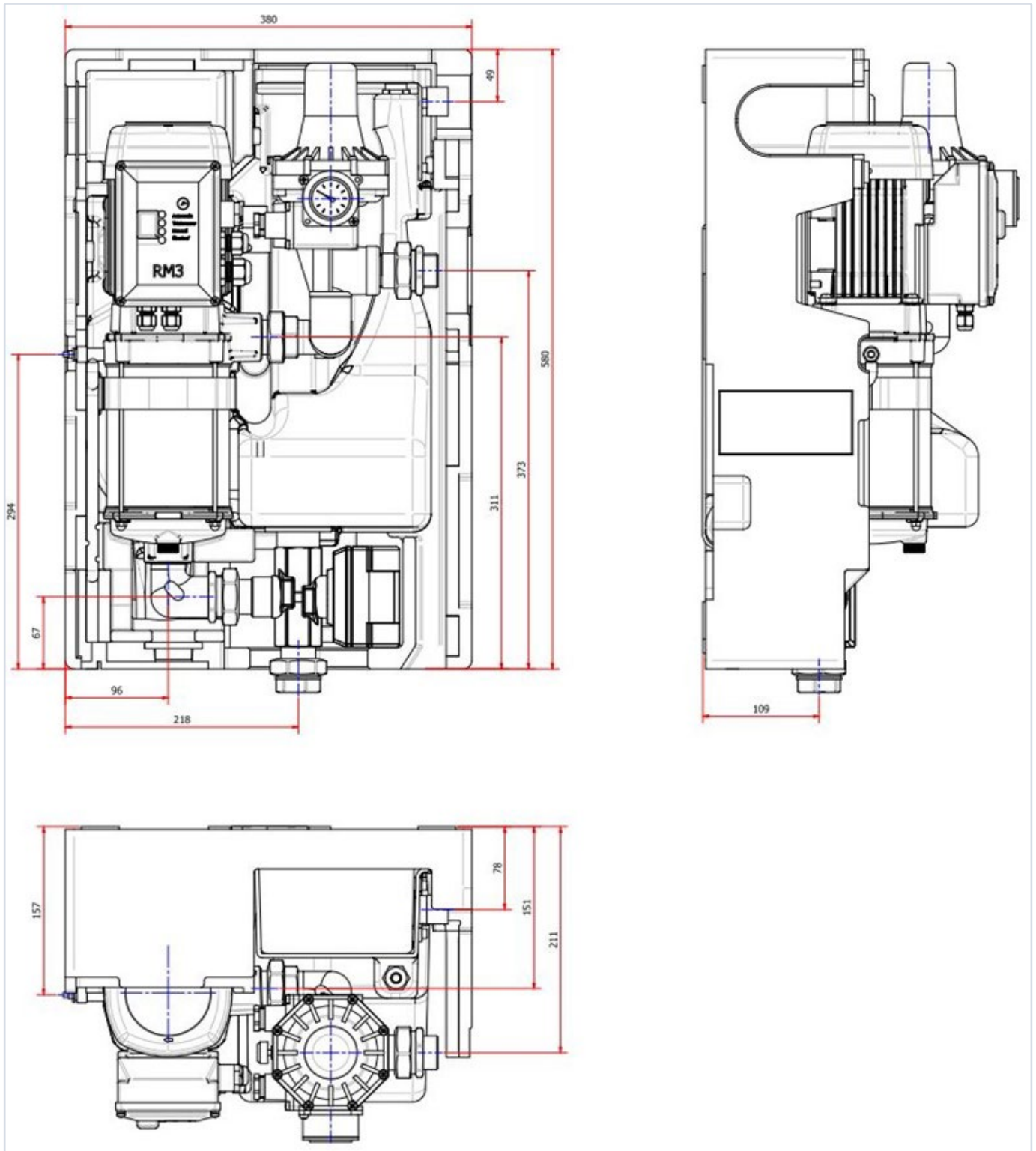

Figure 3: Connecting dimensions



### 3.6. Intended use

The *Rain Manager* shall be operated only in applications described in this manual. Any use of the *Rain Manager* for purposes other than the intended use can cause harm to persons, neighbouring facilities and the environment.

- ▶ Operate the *Rain Manager* in a perfect technical condition only.
- ▶ Never use the *Rain Manager* in a partially assembled condition.
- ▶ Do not use the *Rain Manager* for fluids other than the fluid described in this manual.
- ▶ Never run the *Rain Manager* without fluid.
- ▶ Do not allow the flow rate to fall below the lower threshold of 1 L/min.  
Lower flow rates at the points of use will cause the pump to be switched on and off excessively often. In such case, install an additional expansion vessel of appropriate size in the delivery line.
- ▶ Observe the indicated maximum flow rates (see Section 4.1) (avoidance of overheating, mechanical seal damage, cavitation damage, bearing damage, etc.,...).
- ▶ Never restrict the *Rain Manager* on the inlet side (avoidance of cavitation damage).<sup>2</sup>
- ▶ Contact the manufacture for any operating modes other than those mentioned in the documentation.

### 3.7. Improper use

Do not use the *Rain Manager* outdoors. The effects of temperature, light and humidity can cause malfunctions and damage to the equipment.

- ▶ Do not use the *Rain Manager* for purposes other than the intended use.
- ▶ Do not draw dirty or sewage-contaminated water.
- ▶ Do not fill any aggressive or combustible fluids into the fluid ports of the system.
- ▶ The temperature of the pumped fluid shall not exceed a maximum threshold of 35° Celsius.
- ▶ Do not subject housings and tanks to mechanical loads (e.g. by placing objects on them or using them as a step).
- ▶ Do not make external modifications to the housings and tanks. Never paint or varnish housing parts and screws or bolts!
- ▶ Do not disassemble the *Rain Manager* to a higher extent than what is needed for installation or maintenance work.



---

<sup>2</sup> Cavitation is the spontaneous formation of voids in hydraulic fluids. Such voids occur in the form of bubbles. Since these bubbles have a vacuum inside, they collapse immediately. This might cause damage to the pump.



## 4. Technical data

### 4.1. Comparison between DEHOUST RM3 and RM5 CONNECT

<i>Rain Manager</i>		DEHOUST RM 3 Connect		DEHOUST RM 5 Connect	
Dimensions / weights / volumes	Article No.	With RM3 connection kit 815240		without RM 5 connection kit 815250	with RM 5 connection kit 815260
	Effective volume of service water tank (L)	4.5		6.0	
	Dimensions H x W x D (mm)	580 x 380 x 295		734 x 596 x 300	
	Required clearance above tank (mm)	400			
	Noise level	approx. 60 dB (A)		approx. 70 dB (A)	
	Total weight (kg)	18		25	
	Total weight with filled storage tank (kg)	25		33	
	Links to drawings on the website				
	Assembly	wall-mounted			
Technologies	Mains water make-up	acc. to DIN EN 1717			
	Mains water make-up category	5			
	Free outlet	Type AB			
	Mains water make-up flow at 2 bar (m³/h)	1.5		1.8	
	Mains water make-up flow at 4 bar (m³/h)	2.7		3.2	
	Dry-run protection	yes			
	Plant controller	fully automatic			
Electrical data	Voltage supply (fusing)	230 V / 50 Hz / 16 A			
	Power input (W)	805		1,510	
	Current input (A)	3.6		6.8	
	Standby (W)	4.6		9.2	
	Floating output	no			
	Class of protection:	IP 42			
	Insulation class	F			
	Network connection	WIFI / BLUETOOTH			
	Condition for network connection	Stable connection without firewall			
Connections	Connection cable (m)	1.5 with protective conductor			
	Rainwater make-up connection	1" external thread			
	Mains water make-up connection	¾" internal thread			
	Overflow connection	DN 50		DN 70	
	Service water delivery line connection	1" external thread		1" internal thread	
	Feeder pump connection	yes		yes	
Hydraulic data	Pressure booster	integrated			
	Max. discharge rate of pump (m³/h)	3.2		4.8	
	Max. discharge rate of double pump (m³/h)	No second pump			
	Max. head (m)	44		68	
	Cut-in pressure (bar)	2.4		1.5	
	Minimum flow (L/min)	1			



## 4.2. Pump characteristics in comparison

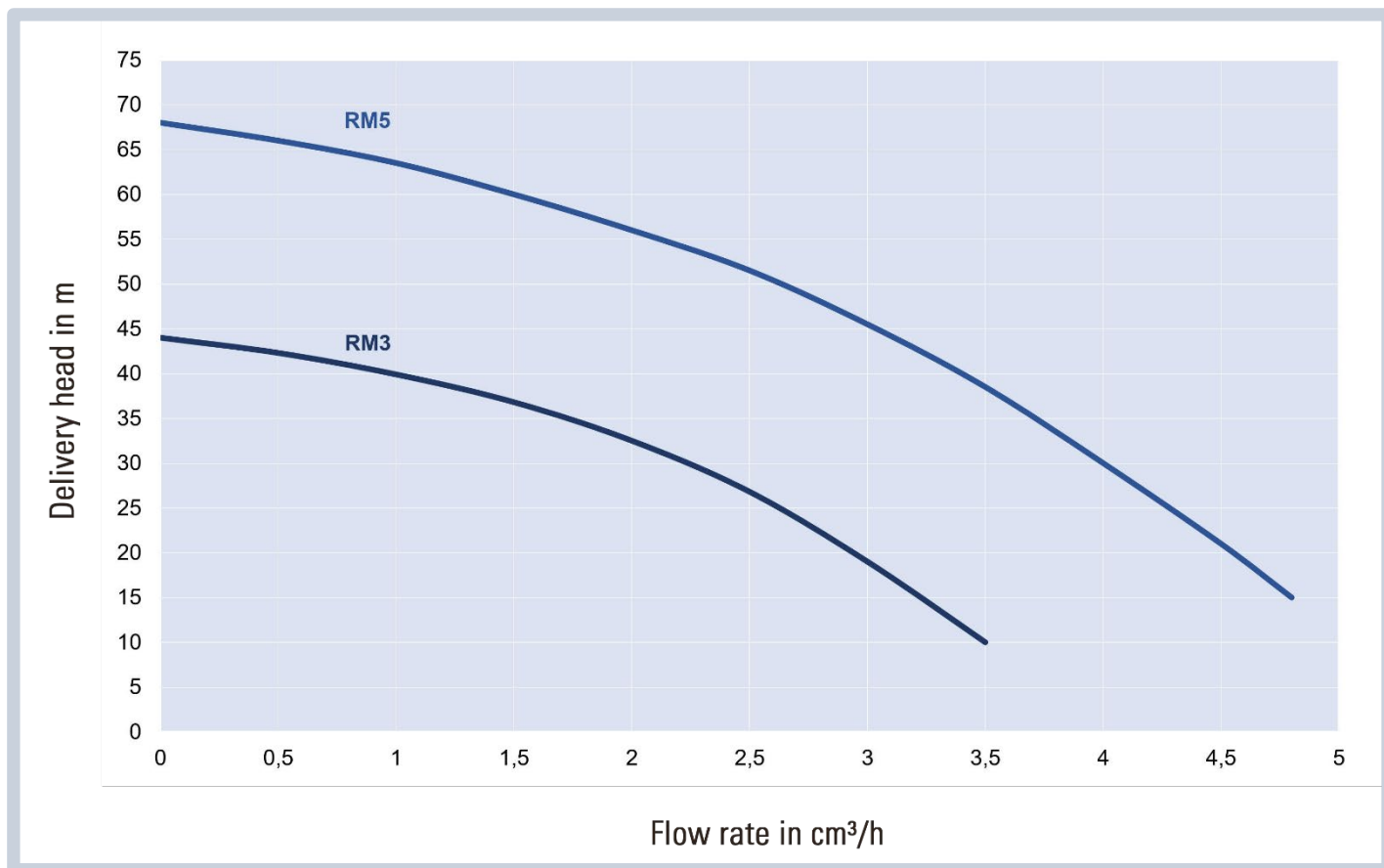

Figure 4: Pump characteristics in comparison / this overview is based on a kinematic viscosity of 1 mm²/s and a density of 1,000 kg/m³



- ▶ The place of installation shall be a dry, frost-proof and ventilated plant room.
- ▶ Temperatures of the pumped fluid shall not fall below 5 °C or rise above 35 °C.
- ▶ Observe the servicing and maintenance specifications laid down in DIN EN 16941-2.

Simply scan the QR-Codes to get directly to the drawings





## 5. Handling and storage / installation

### 5.1. Transport

Transport the system in a dry and cool environment protected from sun and frost. Ensure that the system is not knocked or dropped during transportation.

Every pack shall be inspected for damage upon delivery. Identify, record and report immediately any transport damage in detail in writing to DEHOUST.



Do not hold or pull the *Rain Manager* by the power cable during transportation.



The place of installation shall be a dry, frost-proof and ventilated plant room.  
Ambient temperatures should not be below +5 °C or above +35 °C.

### 5.2. Requirements for the place of installation

Before installing the *Rain Manager*, make sure to consider that the backflow level must be observed when connecting it to the sewer system at a later date; see Section 6.3.4 Connecting the emergency overflow.

- ▶ Install the *Rain Manager* in a frost-free, dry, cool and properly ventilated room protected from sunlight.
- ▶ The room must have a floor drain connected to the sewer system.
- ▶ The room temperature shall not exceed the maximum admissible temperature (cf. Section 5.1) to minimize hygienic risks in the service water storage tank.
- ▶ Fix the *Rain Manager* in a horizontal position to a flat wall to avoid malfunctions and/or distortions in the system. The load-carrying capacity of the wall must match the total weight of the *Rain Manager* in its filled operational condition (cf. Section 4.1).
- ▶ An overhead clearance of no less than 400 mm between tank covers and room ceiling must be maintained for maintenance and inspection purposes.
- ▶ The lower edge of the *Rain Manager* must be installed approx. 300 mm above the maximum water level in the collecting tank (e. g. cistern, underground tank, basement tank). For sewer connection, observe the backflow level (see Section 6.3.4).



It is absolutely necessary for the place of installation to have a suitable floor drain or pump sump to be able to safely discharge overflowing water amounts through the free emergency overflow of the service water storage tank in case of a backflow situation.

Should it be impossible to install the *Rain Manager* at a height above the maximum water level of the rainwater cistern, please contact DEHOUST.



- ▶ Do not operate the *Rain Manager* in close proximity to living or bedrooms because of water make-up and pumping noise.
- ▶ Ensure there is enough space for operation and maintenance.



## 6. Assembly

### 6.1. Wall installation

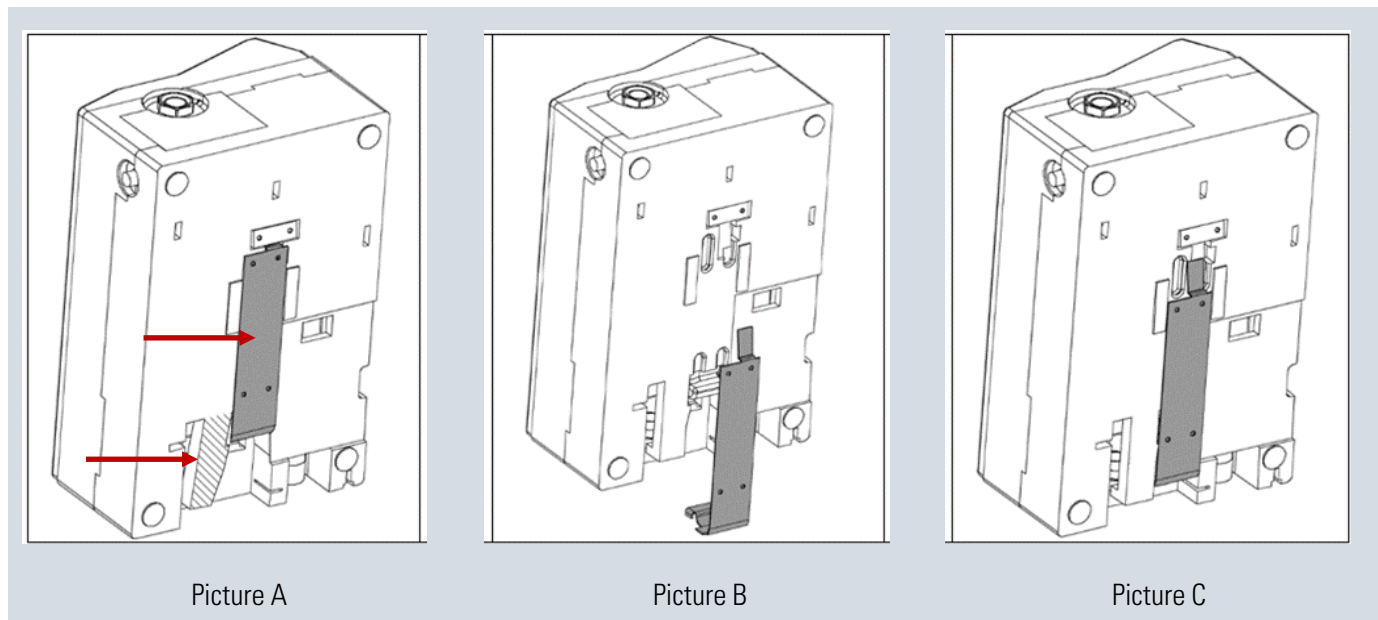

For transportation reasons, the wall mount is delivered inserted in its recess in the rear panel of the *Rain Manager*. Therefore, it is necessary to remove the wall mount before installing the device on the wall.

- ▶ In order to remove the wall mount, bend the lower mounting strap – hatched area in Picture A – toward the side and withdraw the wall mount (grey) toward the bottom.
- ▶ Hold the unit against the intended position on the wall and mark the top left corner/intersection points.
- ▶ Place the drilling template against the previously marked intersection points, align it with a spirit level and mark out the fixing holes for the wall mount.
- ▶ Drill the fixing holes using an 8 mm bit and insert the dowels.
- ▶ Align the wall mount to a flat and vertical position to prevent malfunctions of the system.
- ▶ Fasten the wall mount with the hexagon head screws and washers included in the delivery.
- ▶ Check the wall mount for a close and tight fit to avoid later damage.
- ▶ Insert the unit from above into the wall mount and check that the recesses are in place in the guides, refer to the rear view in Pictures B and C on top.
- ▶ Ensure that the device is properly seated in the guides of the wall mount and slides all the way down until it can be felt to engage the mounting strap.



## 6.2. Removing the housing front

Before connecting the *Rain Manager* to the water pipes, it is necessary to remove the housing front of the device:

- ▶ Withdraw the housing front along the peripheral edge from the rear panel. Attention: Do not skew the housing front.
- ▶ Remove the cover of the mains water tank.
- ▶ Connect the flexible reinforced hose tightly and firmly to the mains water filter using the 3/4" external thread coupling.
- ▶ Connect the cap ring of the reinforced hose tightly and firmly to the float valve of the *Rain Manager* using the gasket included in the delivery.
  - ▶ Ensure that the pipe joint is in exact alignment to prevent distortions in the device.
  - ▶ Do not twist or bend the float valve when installing the mains water line; where necessary, use a wrench on the wrench flats of the float valve to hold it firmly in place – as shown in the illustration (bottom/black).
- ▶ The float of the float valve must be aligned in a vertical position in the mains water tank – as shown in the illustration (bottom/grey).
  - ▶ The float must be able to move freely along the vertical direction.
  - ▶ The float valve must have been properly pressed into the retainer clip.
- ▶ Install the first pipe clamp no more than 10 to 15 cm away from the *Rain Manager*.
  - ▶ This is important for avoiding pipe movements due to pressure changes, potential vibrations in the drinking water mains when the float valve is closed and potential noise transmission into the building.
- ▶ Put the cover back in place on the mains water tank.
- ▶ Slip the housing front back in place or keep the unit open for further installation work.

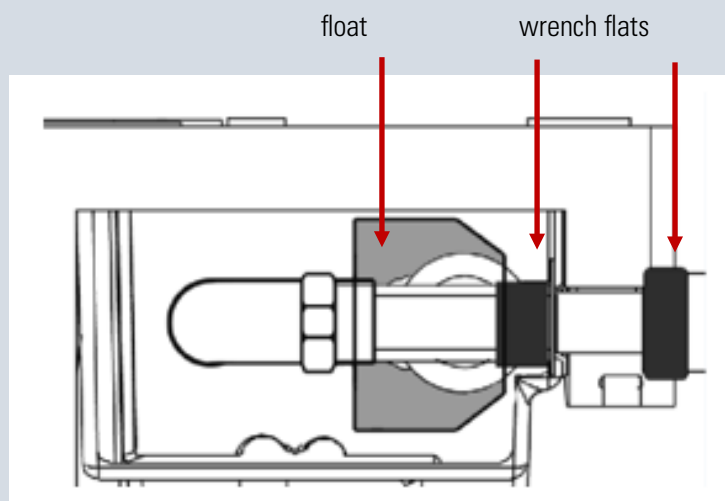

Figure 5: Internal view of mains water make-up



### 6.3. Connection to water pipes

All connections of the *Rain Manager* are provided with three-part brass pipe unions which will facilitate future maintenance and repair.

The delivery includes a “connection kit” allowing for flexible connection of the different pipes. As a result,

- ▶ transmissions of vibrations and noise are avoided
- ▶ mounting inaccuracies are compensated
- ▶ the pipes can be shut off at all times
- ▶ malfunctions can be eliminated at low cost
- ▶ repair and maintenance work can be done at all times
- ▶ water inflow can be stopped for longer absence from home

In order to avoid an increase in pressure due to thermal expansion in the discharge pipe, it is necessary to install an appropriate expansion vessel in the delivery line. Depending on the use case (such as drip irrigation in a garden), installing a separate membrane expansion vessel should also be considered. Installing such a vessel will avoid “cycling” of the pump.



- ▶ Continuous cycling of the pump can cause failure of the pressure switch first and then the pump will keep running without being switched off. If there is no water, the pump will be damaged beyond repair.
  - ▶ Use an appropriate design program of the vessel manufacturer to properly dimension the membrane expansion vessel.
-



### 6.3.1. Connecting the mains water make-up valve



- ▶ Connect and seal the mains water line to the mains water connection on the top right side of the *Rain Manager*.
- ▶ The design pressure of the float valve is from 3.0 bar to 4.0 bar maximum.  
For pressures above 4.0 bar in the mains water inlet, an appropriate pressure reducer needs to be installed.
- ▶ Higher pressures in the mains water inlet can lead to malfunctions in the *Rain Manager* (such as emergency overflow).

We recommend that the building owner installs a stop valve, and the flexible reinforced hose delivered with the RM3 controller.

When dimensioning the mains water inlet, ensure that there is enough make-up water available. The make-up flow can reach up to 3 m<sup>3</sup>/h, depending on the use.

The delivery includes a drinking water filter with a mesh size / filter rating of 110 micrometres (0.11 mm) to provide permanent protection against contamination of the float valve with dirt or lime particles from the mains water line.



The mains water make-up volume must be within the specified flow pressure range (see Section 4.1) to be able to guarantee for a permanently sufficient water supply to the pressure pump.



- ▶ Flush the mains water lines before connecting them to the device.
- ▶ If the hardness of the drinking water is > 20 dH, install a water softener.



## 6.3.2. Connecting the service water delivery line

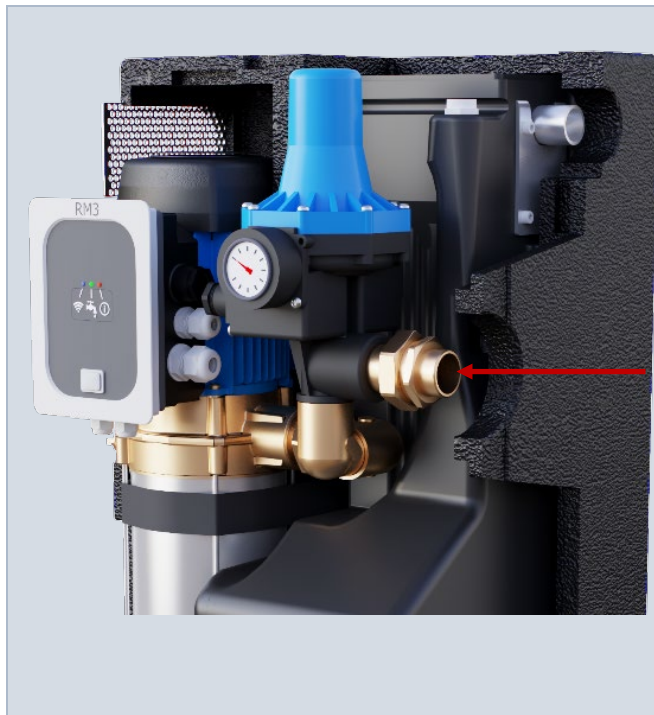

- ▶ Connect the cap nut of the reinforced hose tightly and firmly to the 1" external thread connection of the three-part pipe union of the Rain Manager.
- ▶ Connect the 1" internal thread fitting of the stop valve tightly and firmly to the 1" external thread of the reinforced hose.
- ▶ Connect the service water delivery line tightly and firmly to the still vacant 1" external thread connection of the stop valve.
- ▶ Connect and seal the service water delivery line such prepared to the right-hand thread three-part brass pipe union of the Rain Manager.
- ▶ Since the three-part pipe union uses an O-ring seal, do not tighten with excessive force; use a maximum (finger-tight) torque of 20-25 Nm.
- ▶ Ensure that the pipe joint is in exact alignment to prevent distortions in the device.

Use pipe clamps to securely fix the delivery line. Install the first pipe clamp no more than 10 to 15 cm away from the *Rain Manager*. This is important to avoid pipe movements due to pressure changes, potential vibrations in the service water system and potential noise transmissions into the building.

The building owner is recommended to install the stop valve included in the delivery of the RM3 controller and the flexible reinforced hose.



- ▶ Connect the delivery line and make sure it is free of stress. No forces shall be applied to the threaded brass coupling of the *Rain Manager*. The building owner should install a stop valve and a releasable threaded connection.
- ▶ Depending on the use case (such as drip irrigation in a garden), installing a separate membrane expansion vessel should be considered. Installing such a vessel will avoid "cycling" of the pump.
- ▶ Continuous cycling of the pump can cause failure of the flow monitor first and then the pump will keep running without being switched off. If there is no water, the pump will be damaged beyond repair. In an early stage, also the pump's starting capacitor can be damaged.
- ▶ The membrane expansion vessel must be suitable for service water operation. The upstream pressure in the membrane expansion vessel must be 0.3 to 0.5 bar below the cut-in pressure of the pump. Use an appropriate design program of the manufacturer for dimensioning the vessel.



### 6.3.3. Connecting the suction line

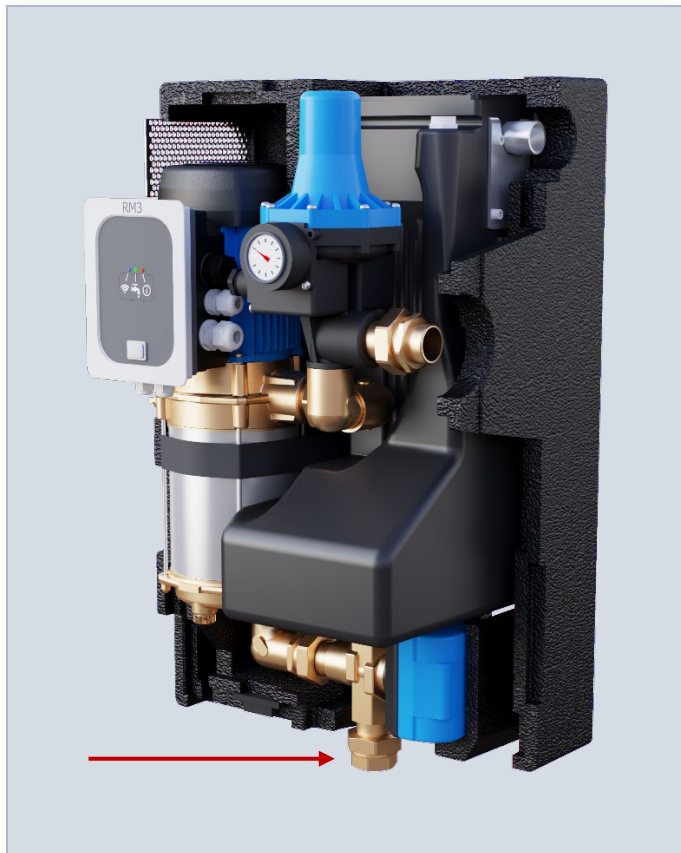

- ▶ Connect the rubber suction hose (included in the RM3 connection kit) tightly and firmly to the already existing suction line from the collecting tank.
- ▶ Connect the rubber suction hose tightly and firmly to the counterpart (internal thread) of the three-part union of Rain Manager.
- ▶ Connect the suction line such prepared to the threaded three-part brass pipe union of the Rain Manager below the unit.

Since the three-part pipe union uses an O-ring seal, do not tighten with excessive force; use a maximum (finger-tight) torque of 20-25 Nm.

- ▶ Lay the suction line in a straight line (direct path).
- ▶ Ensure that the pipe joint is in exact alignment to prevent distortions in the device.
- ▶ Use pipe clamps to securely fix the suction line.
- ▶ Tighten the installed pipe unions or any required pipe clamps with sufficient force to prevent the system from drawing borrowed air later in the rainwater mode and entering the fault mode.



Dirt can get into the suction line during installation. For safety reasons, flush the suction line before connecting it to the device!

A check valve is installed between the *Rain Manager* and the collecting tank. This valve, as an optional accessory item that can be purchased separately, is included in the "*DEHOUST-TWIST/SAFF* Floating Intake" (Art. No. 810540, 810541, 810542 or 810543) or in the "*House Connection Kit*" (Art. No. 812319).

For connecting the suction line, use a tube/pipe (e.g. PE) having a diameter of at least 1" in order to reduce pipe friction loss.

Lay the suction line in a continuous upward slope up to the device. Acceptable length and height differences can be seen from the table on the next page.



Install the first pipe clamp no more than 10 to 15 cm away from the *Rain Manager* to avoid pipe movements in case of pressure changes, vibrations in the service water system and potential noise transmissions into the building.

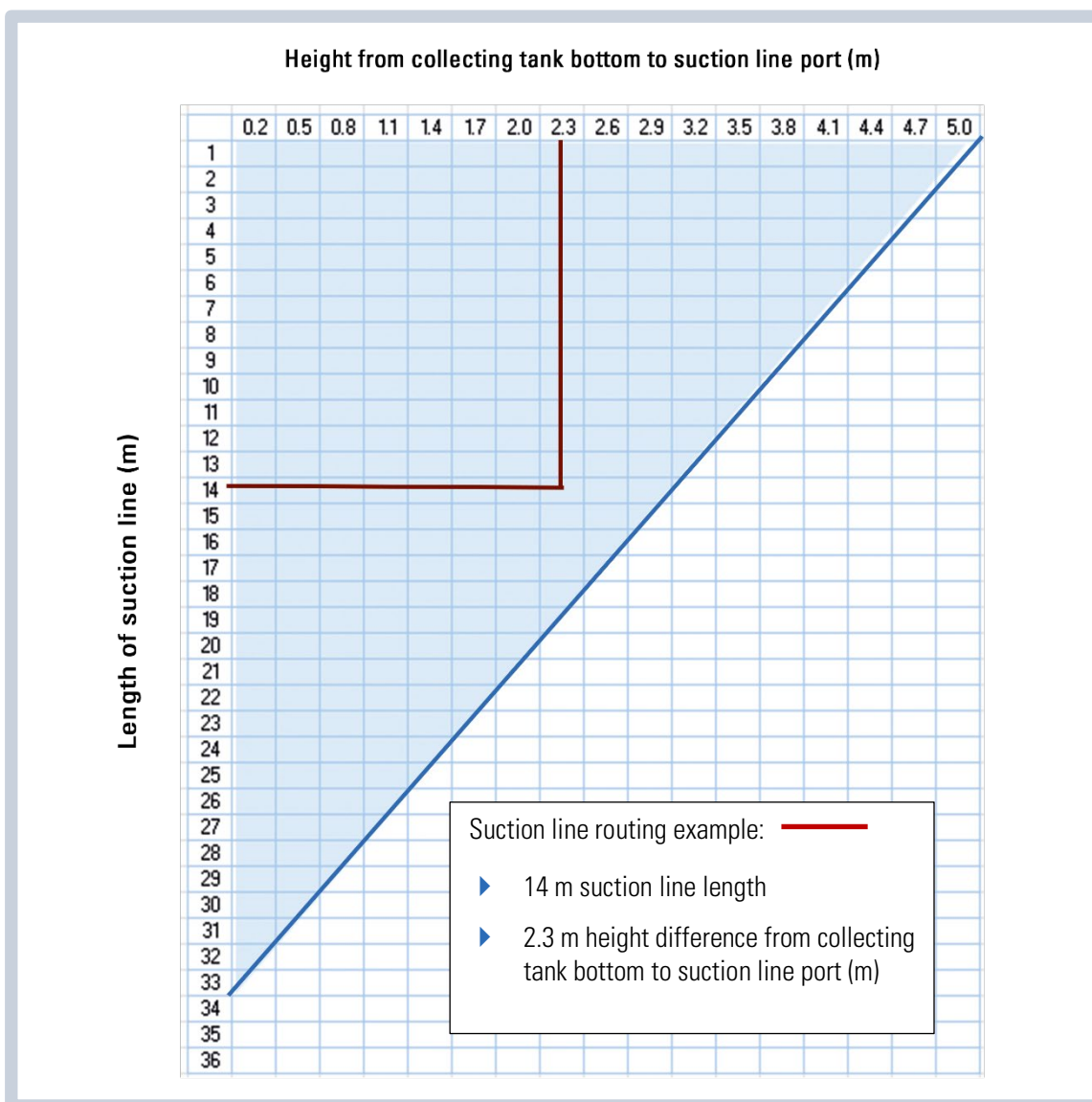

Figure 6: Relation between the length of the suction line and the height from the bottom of the collecting tank (e.g. cistern / underground tank) to the connecting suction line; design basis of the table: 1" PE suction line (25 mm inner diameter) with a use-dependent maximum peak flow of 3 m<sup>3</sup>/h.



Operating the system outside the grey region can cause pump failure in the system.

Where it is desired to run the system outside the grey region, a feeder pump must be retrofitted. The initial pressure of the feeder pump (article no. 814222) covers the friction losses.

If a feeder pump is needed, it is absolutely necessary to provide a conduit between the cistern and the place of installation of RM3. Subsequent installation is hardly possible, if at all.



When installing the suction line, keep the difference in height and length as small as possible.



### 6.3.4. Connecting the emergency overflow

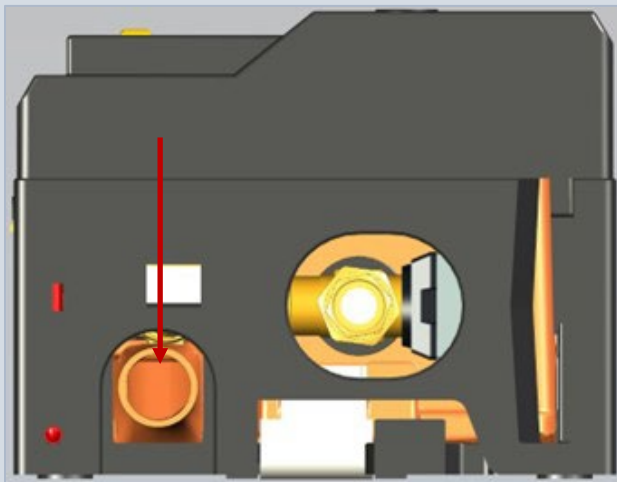

Figure 7: RM3 bottom view

- ▶ Pass the DN 50 drain pipe of the device (see picture) over an unrestricted drop section of at least 50 mm and a downstream DN 70 funnel into the sewer or sewage lifting station.
- ▶ An additional siphon can be used as a drain trap downstream of the funnel.
- ▶ Ensure that the DN 70 downstream pipe maintains the nominal width and a vertical drop section of at least 50 cm before a pipe bend is provided, if any. Otherwise, the water will not drain properly in case of an overflow.

If the *Rain Manager* is installed below the backflow level<sup>3</sup>, the overflow must be directed to a sewage lifting station which passes the water through a piping loop above the backflow level into the sewer.

The overflow will become effective if the mechanical float valve of the mains water make-up shows a malfunction thereby causing the water to rise above the maximum level in the service water storage tank.



The sewer drain or sewage lifting station must be capable of safely discharging the maximum amount of make-up mains water (cf. Section 4.1).

Install the overflow line down to the sewer/sewage lifting station with the same nominal width as the emergency overflow fitting (no cross-sectional constriction!).

Failure to connect the overflow fitting to the sewer drain results in a risk of flooding the installation room.



It is advisable to install a siphon in the sewer overflow to avoid bad odours.

<sup>3</sup> highest possible wastewater level of an overflowing sewage system. It is typically the same as the road level. Information can be obtained from the building authority.



### 6.3.5. Emergency overflow type AB

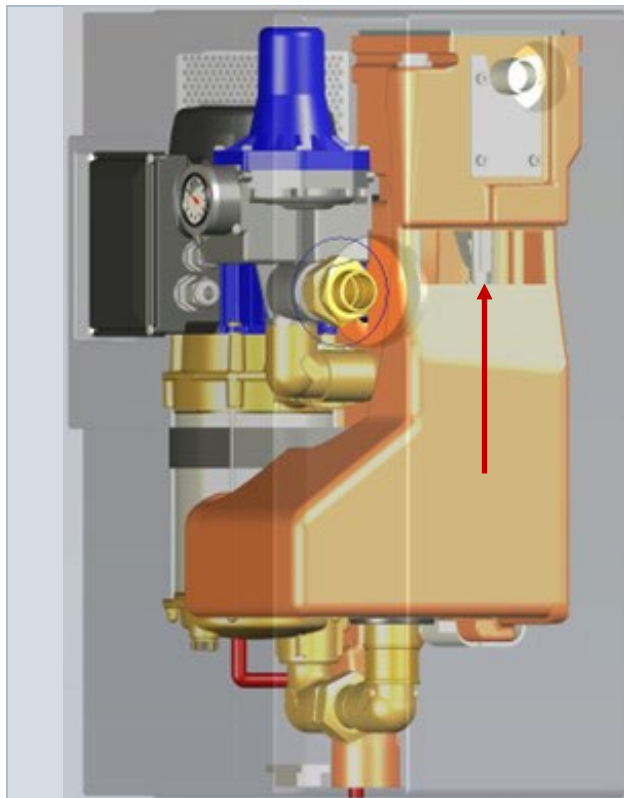

- ▶ In case of backflow into the service water tank of the Rain Manager, e.g. due to sewer backflow / malfunction of the sewage lifting station, the water will be drained through the lateral emergency overflow slot into the installation room.
- ▶ This open overflow is mandatory acc. to DIN EN 1717 for protecting the mains water line.



It is absolutely necessary for the place of installation to have a suitable floor drain or pump sump to be able to safely discharge the amount of water overflowing through the emergency slot in case of a backflow situation.



## 6.4. Electrical connections



Work on electrical equipment shall be carried out by qualified electricians only (see Section 1.6).

### 6.4.1. Connecting the float switch

<p><b>B</b> Drill the fixing hole for the cable clamp above the maximum water level of the collecting tank and insert the dowel.</p> <p><b>A</b> Insert the cable of the float switch into the cable clamp and fix the clamp loosely with the screw in the dowel.</p>	<p>Pull the float switch upward until the distance between the float and the tank bottom is 12 cm.</p>	<p>Tighten the cable clamp until the cable is securely fixed and cannot slip.</p>



The float switch must not come into contact with any obstacles, such as the tank wall or the calmed inlet, in the collecting tank; otherwise the system may malfunction.



## 6.4.2. Connecting the float switch cable

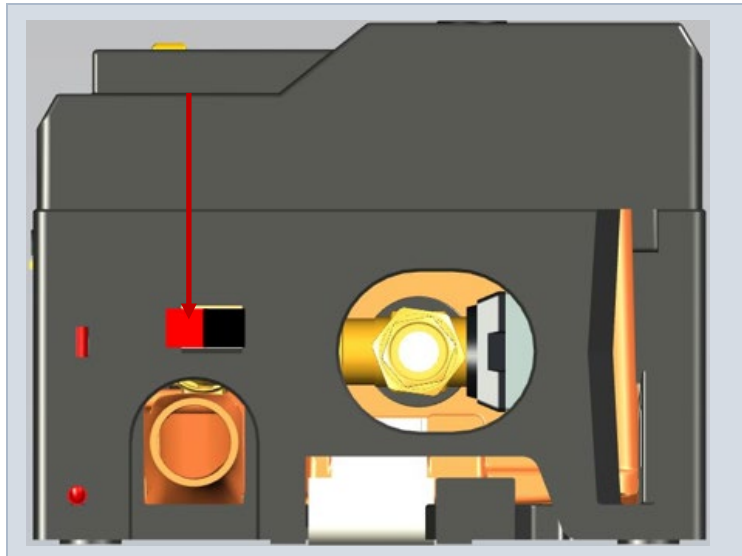

- ▶ Connect the cable to the device. The *Rain Manager* is equipped with contact terminals for easy connection.
- ▶ Insert each of the stripped cable ends into one of the terminals of the *Rain Manager* – colours do not matter.
- ▶ Secure excess cable to the wall using cable clamps.



Do not lay the cable in the ground without protection.

Acceptable solution: Connect the collecting tank to the house using a DN 100 underground pipe, then lay and protect the cables inside.



Check the float switch for correct installation and proper function. Check the cable for kinks, cracks or other problems.

## 6.4.3. Connecting the system

- ▶ Work on electrical equipment shall be carried out by qualified electricians only (see Section 1.6).
- ▶ All electrical components on the *Rain Manager* have been wired at the factory.
- ▶ Check the voltage information given on the type label against the actual supply voltage of the local power mains.
- ▶ The electrical connection of the power cable on the *Rain Manager* is in accordance with the specifications mentioned at Section 3.1 and is made by connecting the power plug to the local mains.
- ▶ Provide fuse protection as indicated on the type label.
- ▶ The system is switched on as soon as the mains plug is plugged in.



The electrical system must be in compliance with the installation provisions of IEC 364 / VDE 0100, i. e. it must have power sockets with protective conductor. The electrical network to which the *Rain Manager* is connected must have a residual current device (RCD) according to DIN EN 60335-2-41 / VDE 0700.

Further specific national standards and laws have priority and must be observed.



## 6.5. WIFI connection



RM3.connect  
[www.dehoust.com/rm3cx](http://www.dehoust.com/rm3cx)  
CNo: 102DC7KVLFW  
PIN: 823849



**Pull power plug before  
opening the housing.**

You need the DEHOUST App and the access PIN for your *Rain Manager* in order to be able to use the WIFI connection.

You find the access PIN on the type label on the side of the RM3 controller.

Figure 8: Sample type label (each unit has its own CNo. and PIN)

You can download the DEHOUST Connect-APP either from our [website](#) or directly from the Apple or Android app stores.

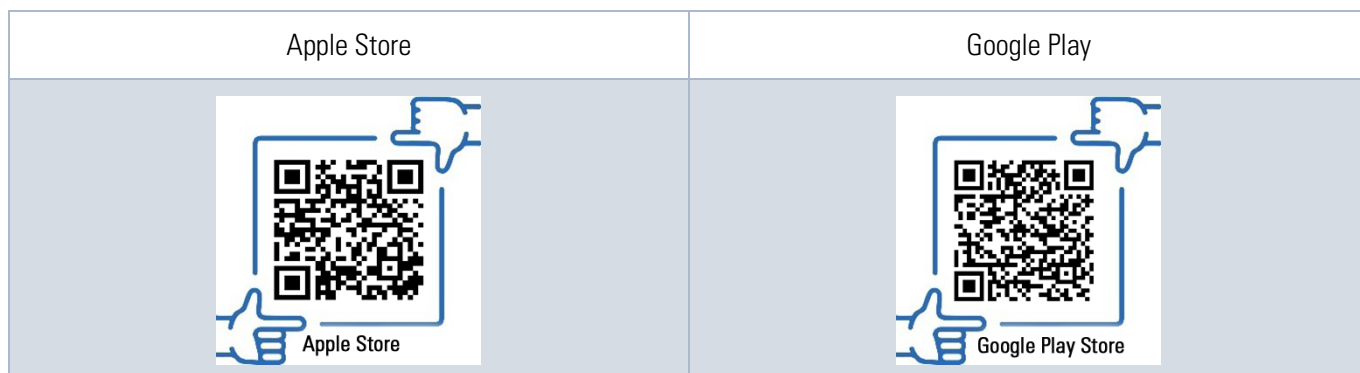

After installation of the app, follow the steps described below to set up the WIFI connection. User access is not required at this point.



<p>The BLUETOOTH function of your mobile device must be activated. Then select the <a href="#">[Connect]</a> icon</p>	<p>Press the three lines menu icon in the top right corner (No user access required so far)</p>	<p>Tap on <a href="#">[Connection Manager]</a></p>
<p>Confirm <a href="#">[Device selection]</a></p>	<p>Confirm the connection with <a href="#">[OK]</a></p>	<p>Read the pairing code on the controller, enter the code and confirm with <a href="#">[Pair]</a></p>

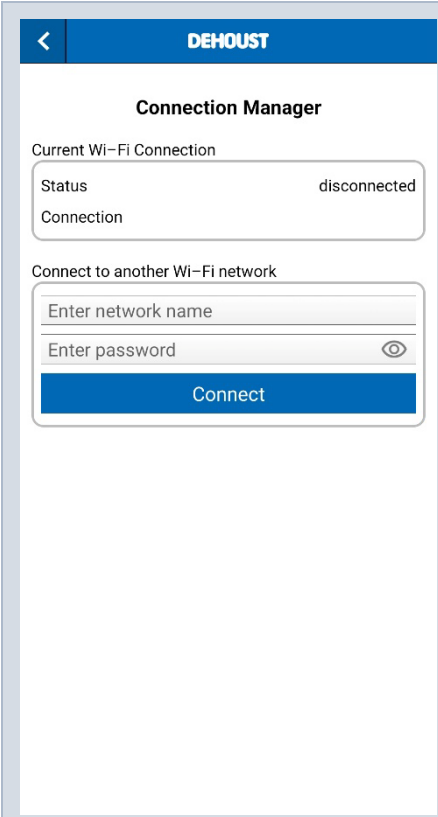
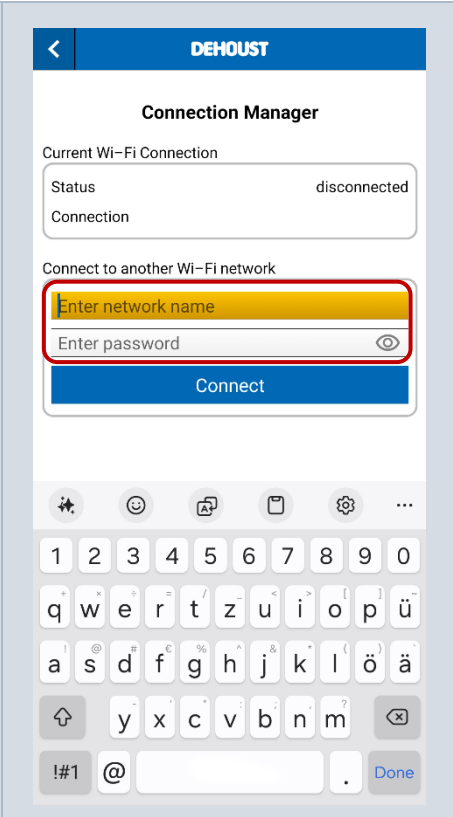
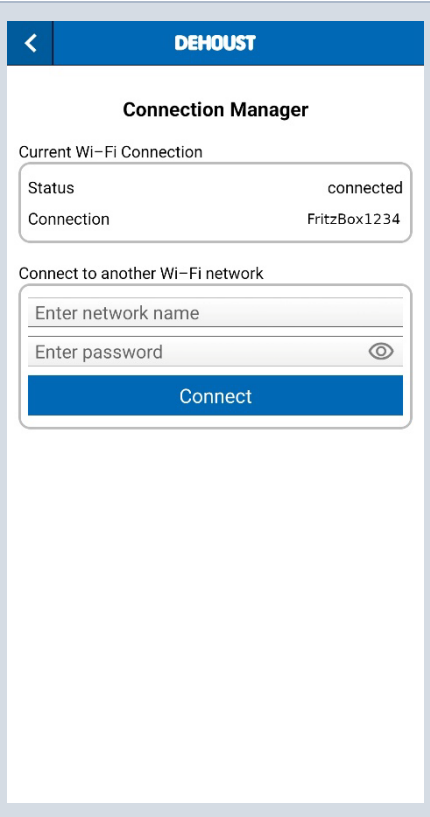

		
	<p>Enter the network name and the password and confirm with <a href="#">[Connect]</a></p>	<p>The connected network will be displayed</p>



## 6.6. Registering the RM3

### 6.6.1. Through the website

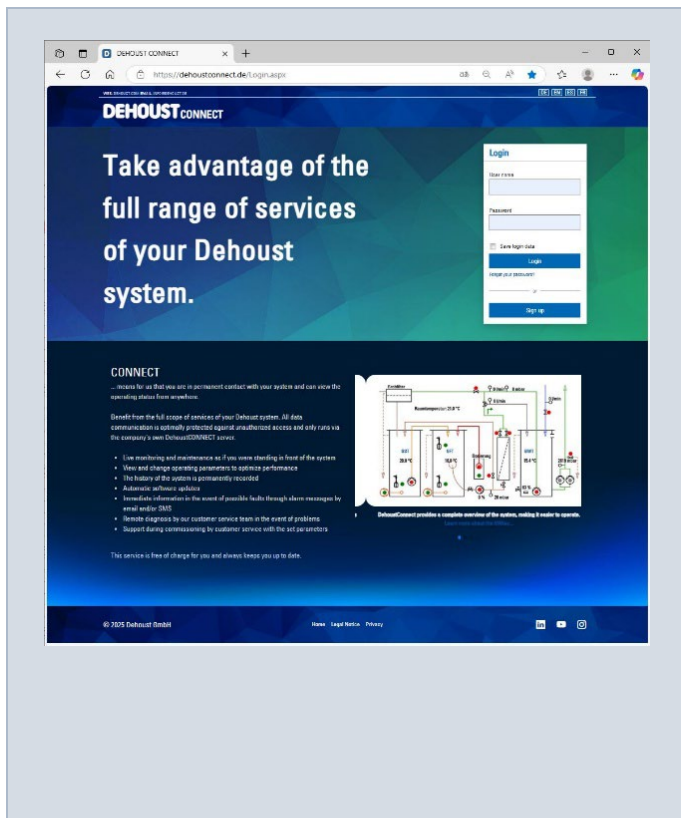

Open the website [www.dehoustconnect.de](http://www.dehoustconnect.de)

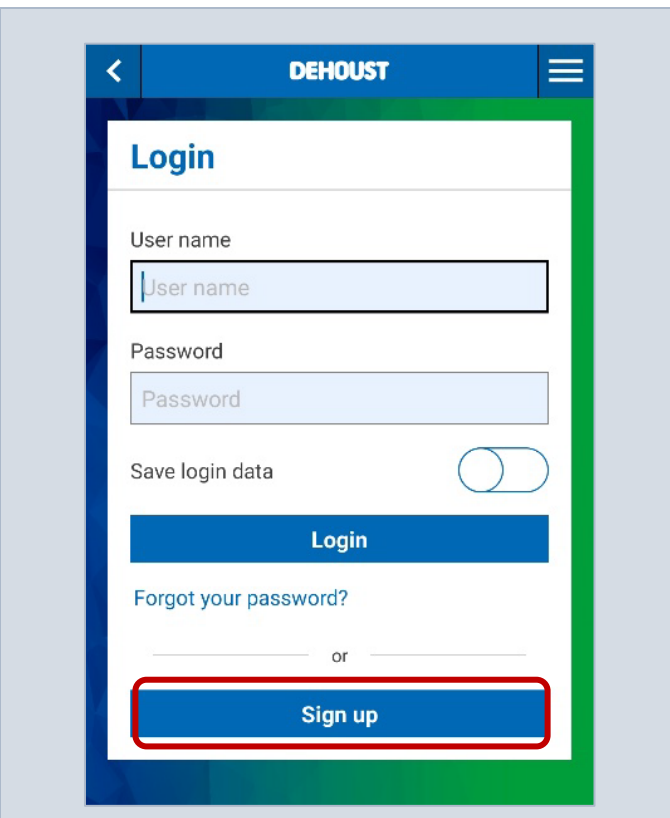

Click on [Sign up]

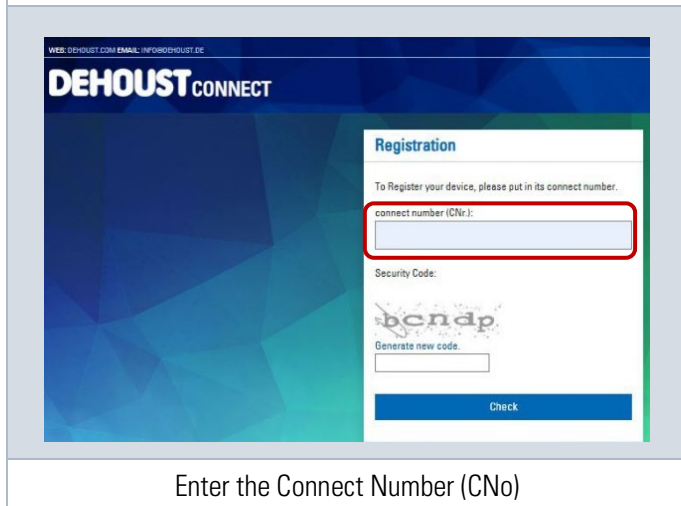

Enter the Connect Number (CNo)

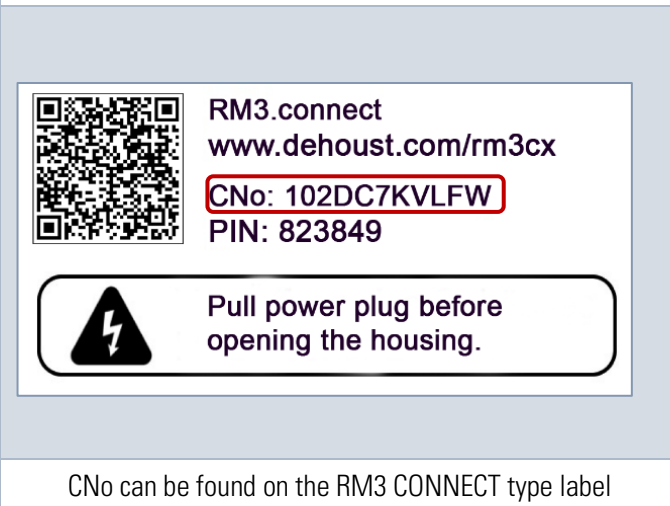

CNo can be found on the RM3 CONNECT type label

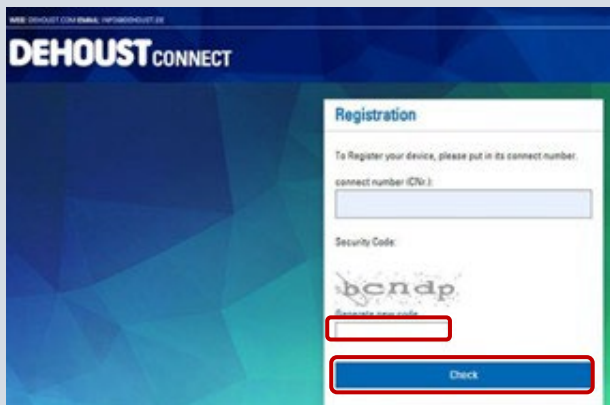

Enter the safety code and click on [\[Check\]](#)

**Registration**

Device data  
Connect number:  
101DCTKVLFW

Project data  
Project Name: \*

Contact details  
Company:  
Title: \*  Mr.  Ms.  
First Name: \*  
Last Name: \*  
Address:  
ZIP: \*  
City:  
Phone: \*  
Email: \*

User data  
Country: \*   
Time zone: \*   
Password: \*  
Password (repeat): \*  
Minimum 8 characters

Privacy policy: \*  
 I have read and agree to the privacy policy.

Data storage: \*  
 I hereby expressly consent to the storage and processing of my data entered above.

[Sign up](#) [Cancel](#)

Fill in the mandatory fields marked with \* and click on [\[Sign up\]](#).

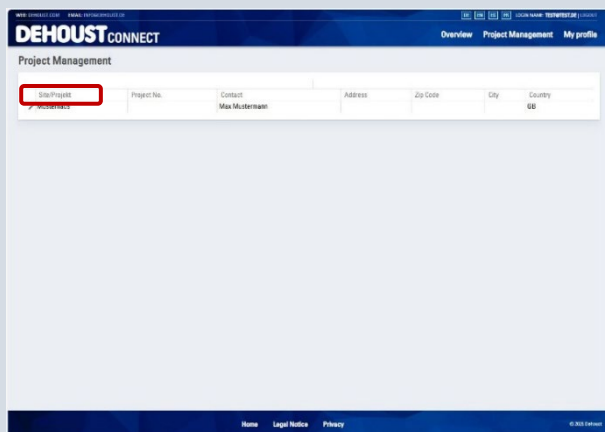

The project created for you will be displayed. Click on [\[Site/Project\]](#) to access the system information

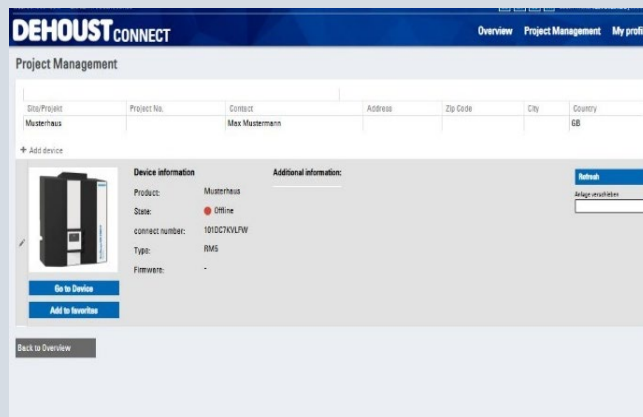

System information view

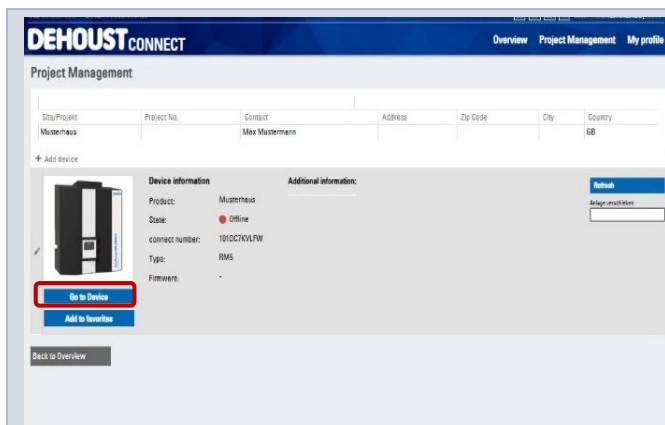

Click on [\[Go to device\]](#) to get access to the *Rain Manager* parameters

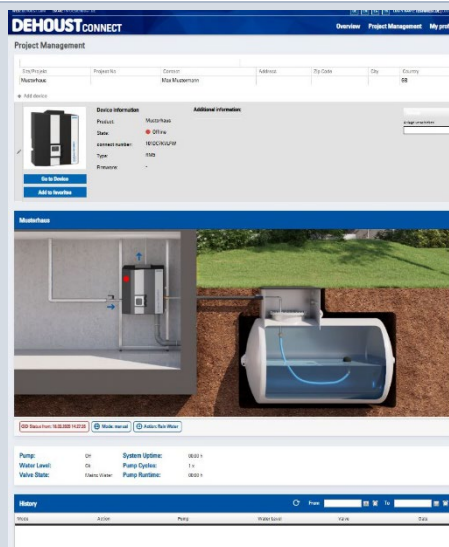

Detailed system information, such as operating status and history of the system, will then be displayed

### 6.6.2. Through the App

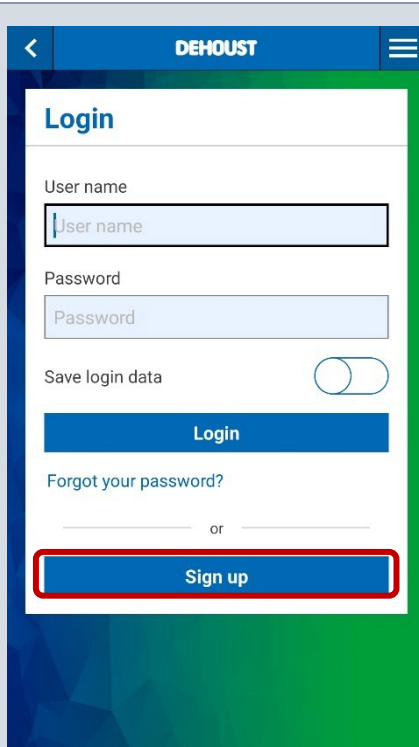
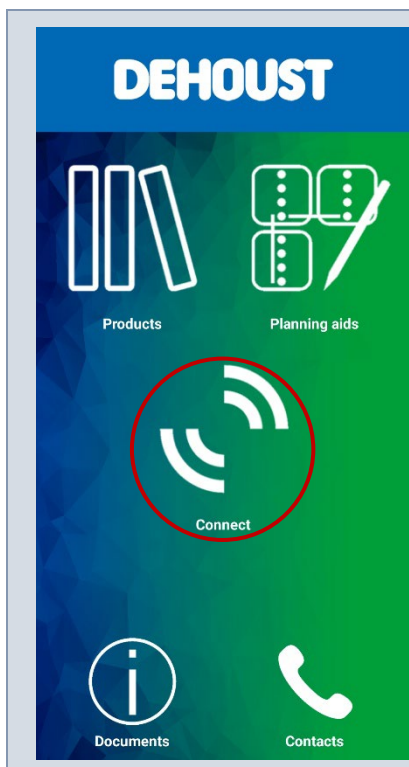

Follow the same registration steps as shown in Section 6.6.1 Through the website.



## 7. Control of components

The *Rain Manager* is provided with 2 control elements that ensure automatic operation and secure water supply in case of lack of rainwater.

- ▶ The RM3 controller monitors and controls the rainwater distribution system. It operates autonomously to detect faults in the rainwater distribution system and takes corrective action to keep it operational. The rainwater distribution system remains operational even when the collecting tank (such as rainwater cistern/underground tank) is empty, as mains water is automatically supplied to the points of use. It is the RM3 controller that switches between service water and mains water; the float switch in the rainwater tank functions as a signal transmitter.
- ▶ The KIT flow switch starts the pump as a function of pressure and stops the pump as a function of flow. It also protects the pump from running dry.

### 7.1. RM3 Controller













	LED 1		indicates WIFI status
	LED 2		indicates operating mode status
	LED 3		information on system status
	Rocker switch		Position 1 = automatic mode Position 0 = mains water mode only

Visible elements include 3 LEDs and a rocker switch with the basic functional indications given above. The table on next page explains the meaning of the different indicating patterns.





### 7.1.1. Explanation of the LED indicating modes at the RM3 Controller

When connecting the *Rain Manager* to the power source, all LEDs briefly light up white before showing light combinations as described below.

LED 1			LED 2			LED 3		
	flashing green	setting up WIFI connection		flashing blue	stagnation protection active		constant green	system in auto mode
	constant green	connected with WIFI (but no Internet, special case)		constant blue	mains water mode		constant blue	system in manual mode
	flashing light blue	setting up Bluetooth connection		constant green	rainwater mode		flashing orange	service water tank overflow
	constant light blue	connected with Bluetooth					flashing purple	backflow alarm
	purple	connected with DEHOUST Connected server (cloud)						
	off	no mobile connection						

### 7.1.2. Manual mode

The rocker switch can be used to change over from automatic [-] = rainwater to manual [O] = mains water.

Rocker switch		LED 2			LED 3		
			constant blue	mains water mode		constant blue	system in manual mode



Water is no longer drawn from the collecting tank.  
The rainwater distribution system is supplied with mains water only.



### 7.1.3. Automatic mode

Rocker switch		LED 2			LED 3		
			constant green	rainwater mode		constant green	system in auto mode



Water is drawn from the collecting tank. The system switches automatically to mains water depending on the water level in the tank.

Rocker switch		LED 2			LED 3		
			constant blue	mains water mode		constant green	system in auto mode



As soon as the pump delivers mains water, because the rainwater tank is empty, LED 2 changes from green to blue.



### 7.1.4. Mains water exchange

After operation in the “Automatic” (rainwater) mode for more than 3<sup>4</sup> continuous days, the RM3 controller changes automatically over to mains water exchange to prevent stagnation of mains water both in the system and in the mains water line. This operation is controlled by the pump current and set to a maximum of 30 seconds.

Rocker switch		LED 2			LED 3		
			flashing blue	stagnation protection active		constant green	system in auto mode



The system changes over to mains water.

After the pump delivers mains water for 30 seconds (with short run times being added up), RM3 changes automatically back to the previous “Automatic” mode; LED 2 stops flashing blue to light up green.

Rocker switch		LED 2			LED 3		
			constant green	rainwater mode		constant green	system in auto mode

<sup>4</sup> The interval can be adjusted via the DEHOUST APP.



## 7.2. KIT FLOW SWITCH



The KIT flow switch starts the pump as a function of pressure and stops the pump as a function of flow and controls the dry-run protection of the pump.

Operating conditions:

- ▶ starting the pump when the pressure drops below 2.4 bar
- ▶ stopping the pump when the flow falls below 1 Litre per minute
- ▶ dry-run protection of the pump in case of water shortage
- ▶ Press the red START or reset button (1) to restart the pump.
- ▶ Pressure gauge (2) for indicating the current service water pressure of the *Rain Manager*.



A big distance / height difference between RM3 and the collecting tank will cause high frictional losses. The pump in RM3 will then no longer be able to draw rainwater from the collecting tank. In such case, it will be necessary to install a feeder pump (DEHOUST Article No. 814222).



## 8. Commissioning

Commissioning work shall be carried out by qualified personnel only (cf. Section 1.6).

### 8.1. Basic conditions

The following conditions must be met before commissioning:

- ▶ The *Rain Manager* is properly connected electrically to all safety and protective devices.
- ▶ The relevant VDE or specific national regulations are observed and fulfilled.
- ▶ The emergency overflow from the *Rain Manager* is connected to the sewer system.
- ▶ The mains water make-up is connected to the drinking water mains.
- ▶ The service water discharge is connected to the service water delivery line.
- ▶ The stop valves for the mains water, suction and service water delivery lines are closed.
- ▶ The float switch has been installed and electrically connected.
- ▶ The external rainwater cistern is at least one third full with water.
- ▶ There is no dirt in the *Rain Manager* and in the pipes.
- ▶ The power plug of the *Rain Manager* is not plugged in.



## 8.2. Step 1: Filling in mains water

It is absolutely necessary to use mains water for the first start-up of the *Rain Manager*. This is why the controller is always set to manual mode on delivery.

### Sequence of operations (please follow the exact order)

- ▶ Open the stop valve at the mains water connection:
- ▶ Open the bleed valve (see illustration/arrow) of the pump with the enclosed socket wrench for approx. 3-4 turns and leave it open for approx. 1 minute.
- ▶ As soon as water emerges from the bleed hose, firmly re-tighten the bleed valve of the pump.
  - ① Then the pump is automatically filled with mains water.
- ▶ Open the stop valve on the delivery side and point-of-use valves (such as toilet flushers, taps) connected to the system.
- ▶ Set the rocker switch of the RM3 controller to [O] (Manual).
- ▶ Insert the power plug of RM3 into a suitable socket having a protective conductor:
  - ① The pump starts automatically.
  - ① LEDs 2 and 3 light blue

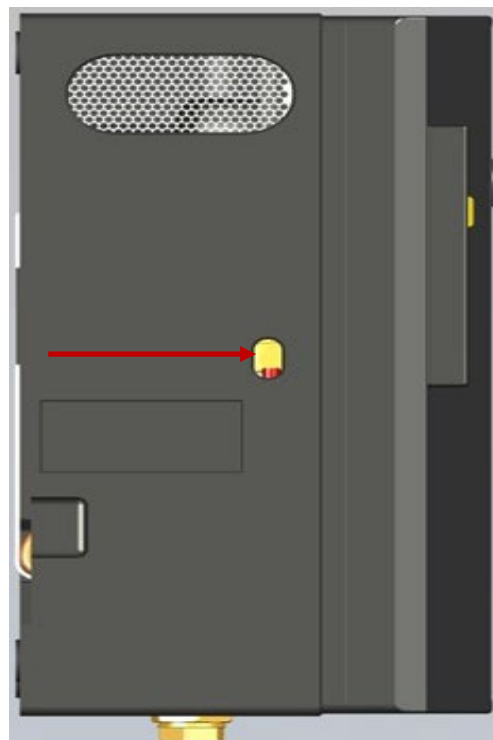



Figure 9: Bleed valve of the pump

Rocker switch		LED 2			LED 3		
	○		constant blue	mains water mode		constant blue	system in manual mode

- ▶ Should the pump fail to start right away, press and hold the red reset button on the flow switch (see Section 7.2) until the pump autonomously builds up a pressure of at least 1 bar.
  - ① The red button overrides the dry-run protection and causes the pump to start.
- ▶ Keep the service water point-of-use valve open until bubble-free water is flowing, then close the valve.
  - ① The pump will stop automatically after a short overrun time (about 15 seconds).
- ▶ The mains water make-up is switched off automatically once the defined maximum water level is reached: The *Rain Manager* is ready for operation.
  - ① In case of a fault at this point, consult Chapter 10 to remedy the fault.



### 8.3. Step 2: Filling in service water



The *Rain Manager* can be started up with service water from collecting tank(s) (such as underground tank / cistern) provided that enough water is available. The **water level must be at least 45 cm**, otherwise top it up accordingly (using mains water).



In order to start up the system with service water, it is absolutely necessary to have performed step 1 with mains water.

#### Sequence of operations (please follow the exact order)

- ▶ Set the controller (Section 7.1) to **[–]** *Automatic* using the rocker switch.  
Attention: Switching takes approx. 10 seconds - please wait this long.
  - ① LEDs 2 and 3 *Automatic* light green

Rocker switch		LED 2			LED 3		
—			constant green	rainwater mode		constant green	system in auto mode

- ▶ Open a point-of-use valve, such as toilet flushers, taps.
  - ① The pump starts automatically.
- ▶ Should the pump fail to start immediately, press the red start or reset button on the KIT flow switch (see Section 7.2). Either press and hold or actuate the button until the water head drawn from the collecting tank is sufficient and the pump continues running on its own to build up a pressure of at least 1 bar. The current value is shown on the pressure gauge (see Section 3.4).



Building up the pressure can take up to 5 minutes, depending on the length of the suction line and the difference in height.

- ▶ Keep the service water point-of-use valve open until bubble-free water is flowing, then close the valve.
  - ① Maximum pressure is built up and the pump stops automatically after a short overrun time (about 15 seconds).
- ▶ Keep the service water point-of-use valve open until bubble-free water is flowing, then close the valve.
- ▶ The *Rain Manager* can now be operated with service water.
  - ① In case of a fault at this point, consult Chapter 10 to remedy the fault.



## 8.4. Step 3: Completion of commissioning

Check all connections for leaks.

Put the housing front back in place. Do not tilt or skew the housing front and ensure that it is flush with the rear panel all the way round.

A recess in the bottom left corner of the rear panel of the *Rain Manager* includes a compartment for documents.

After the completion of commissioning, the installation and operation manual shall be kept here accessible at all times for later consultation.

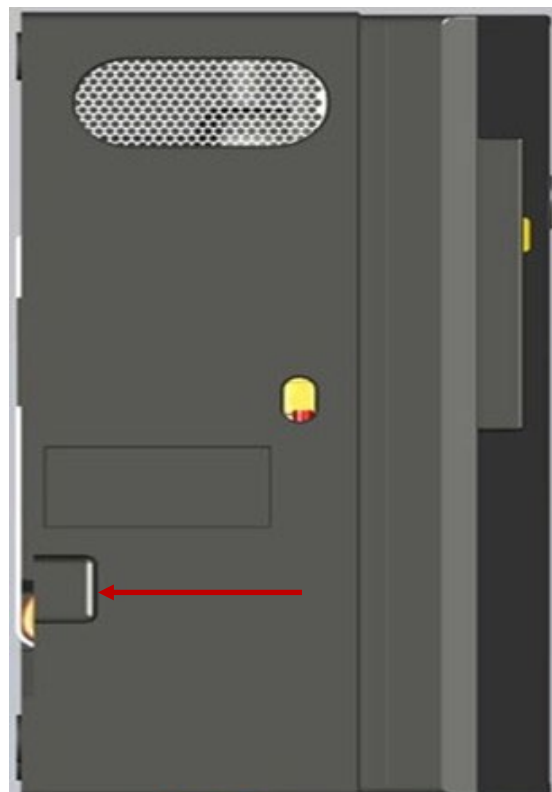

Figure 10: Document compartment for the manual



## 8.5. Documentation

### 8.5.1. Commissioning Sheet

**DEHOUST**

**Commissioning Sheet**  
Version 1.0 | June 2025 | Subject to change

Based on DIN EN 16941-1:2018-06 | EN 16941-1:2018 (D)

**FACILITY ADDRESS**

Postal code      City      Street, House Number

**FACILITY OWNER**

First name/ last name or company name      Postal code      City

Owner's comments

- ▶ All necessary instructions for operating the system have been provided.
- ▶ Technical documentation and existing operating and maintenance manuals have been provided.

**PERSON RESPONSIBLE FOR COMMISSIONING**

First name      Last name

Comments from the person responsible for commissioning

The person responsible for commissioning (or their representative) hereby confirms that installation has been carried out in accordance with the manufacturer's specifications and that the system is fully operational. The commissioning report, which forms an integral part of this declaration, can be viewed on the reverse side.

Date of commissioning      Signature of the above-mentioned person responsible for commissioning

www.dehoust.com  
info@dehoust.de

**DEHOUST**

**Test Report**  
Version 1.0.2025 | Subject to change

Description	Details	Checked	Comments
Roof type	Select	<input type="checkbox"/>	
Pre-treatment and/or pre-filter on inlet side available		<input type="checkbox"/>	
Rainwater tank	Material Select	<input type="checkbox"/>	
	Calm inflow	<input type="checkbox"/>	
	Floating suction	<input type="checkbox"/>	
	Maintenance access	<input type="checkbox"/>	
Overflow tank	Safe access	<input type="checkbox"/>	
	Sufficient drainage capacity	<input type="checkbox"/>	
When connected to drainage system	Protection against small animals (traps)	<input type="checkbox"/>	
	Backflow valves	<input type="checkbox"/>	
No cross-connections with the drinking water system	Backflow prevention (free outlet)	<input type="checkbox"/>	
Pump operating mode <input type="checkbox"/> submerged <input type="checkbox"/> Not submerged			
Non-drinking water pipes clearly marked		<input type="checkbox"/>	
Markings at the rainwater extraction point		<input type="checkbox"/>	

www.dehoust.com  
info@dehoust.de



The Commissioning Sheet can be obtained from the manufacturer as a fill-in PDF file.





## 9. Maintenance

The *Rain Manager* includes components in need of inspection or maintenance.

- ▶ Inspections may be carried out by the operator of the system.
- ▶ Maintenance or repair work shall be carried out by qualified personnel only (cf. Section 1.9).



It is in the operator's own interest to observe and follow the specified inspection and maintenance intervals and operation procedures.

### 9.1. Inspections

In case of defects or damage identified during an inspection of the *Rain Manager*, contact your contract dealer or DEHOUST.

#### 9.1.1. *Rain Manager* RM3 housing



Check the *Rain Manager* housing is clean and properly attached. Remove dirt with a damp cloth and commercially available dishwashing liquid.



When cleaning, ensure that fluids do not penetrate into the electrical parts.

#### 9.1.2. *Rain Manager* RM3 service water tank



Check the service water tank for leaks, dirt, damage and sediments. Remove dirt on the outside with a damp cloth and commercially available dishwashing liquid.



When cleaning, ensure that fluids do not penetrate into the electrical parts.

#### 9.1.3. Inspection of water connections

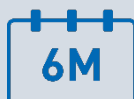

Check the mains water, rainwater and service water connections for damage, leaks and porosities or scuffing marks. Where necessary, replace and seal hoses/lines as required.



## 9.1.4. Float valve of mains water make-up



Check the mains water make-up float valve for leaks and proper function.

Use the rocker switch of the controller to change over to the “Manual” mode [O] (see Section 7.1 RM3 Controller).

Open a point-of-use valve and allow for the water level in the *Rain Manager* to go down until the float valve opens properly. Close the point-of-use valve again and wait until the float valve properly closes again.

Change to the [-] mode using the rocker switch (see Section 7.1 RM3 Controller).



Lime deposits can cause early wear in the float valve, depending on the lime level / hardness degree of the mains water. In such case, replace the float valve (see Section 9.2.1)

## 9.1.5. Rain Manager RM3 Controller



Check for correct switching between the mains water tank and the rainwater tank.

To do so, set the rocker switch of the RM3 controller to “Manual” [O] (see Section 7.1) and check that the pump draws mains water. Return to Automatic [-] and check that rainwater is drawn. Also see Section 9.1.8.

## 9.1.6. Pump with flow switch



Check for pressure build-up, leaks, running and flow noise, and functions. To do so, press the red button on the flow switch briefly until the pump is starting (see Section 7.2).

## 9.1.7. Service water tank seal



Check that the rubber seal between the service water tank and the pump suction line is correctly seated and sealed.

## 9.1.8. Three-way zone valve



Check that the zone valve between the mains water tank and the rainwater tank is properly working.

To do so, set the rocker switch of the RM3 controller to [O] (see Section 7.1) and check that the pump draws mains water (also see Section 9.1.5). Return to Automatic [-] and check that rainwater is drawn.

In case of valve failure, contact the manufacturer.



## 9.2. Maintenance



Disconnect the *Rain Manager* from the power mains before starting any maintenance and repair work. The *Rain Manager* is not available during such work.

### 9.2.1. Replacing the float valve



Lime deposits can cause early wear in the float valve, depending on the lime level / hardness degree of the mains water.

In such case, replace the float valve (an appropriate replacement is available under Article No. 811903 in accessories). The replacement valve is delivered with the installation instructions.

### 9.2.2. Mechanical seal / bearings of the pump



We recommend replacing the mechanical seal after **10,000 operating hours or no later than after 10 years**. The mechanical seal shall also be replaced in case of early wear.



## 10. Malfunction / fault detection

---



Always disconnect the *Rain Manager* from the power source (pull the power plug) before starting any corrective actions.

---

If you intend to remove the unit from the wall, whether for troubleshooting or other work, or to empty the pump, first:

- ▶ Set the controller to [O] (manual mode).
  - ▶ Shut off the mains water feed.
  - ▶ Wait at least 10 seconds before disconnecting / isolating the *Rain Manager* from the power supply. This waiting time is important to ensure that the zone valve changes entirely to mains water thereby allowing the pump to be filled automatically when the system is restarted.
  - ▶ Open a point-of-use valve, such as a toilet flusher. The pump starts automatically to empty the service water tank.
- 



To take the *Rain Manager* down from the wall, follow the first wall installation steps described in Section 6.1.

---



The following tables show fault indications or malfunctions and how to correct them.  
For any faults or malfunctions other than those listed, please contact your dealer / distributor.

---



## 10.1. Fault indications at the controller

Fault indicated at the RM3 Controller	Possible causes	Measures & Actions	Responsible
LED 2 and LED 3 green on controller in addition: KIT pressure gauge = 0 bar	Pump has run dry	<ul style="list-style-type: none"><li>▶ Check the fill level in the collecting tank and the installation of the float switch and floating intake or check valve. Then restart the system, see Chapter 8</li><li>▶ Check the float valve and its supply line.</li><li>▶ Check any additional stop valves in the feed line. Then restart the unit, see Chapter 8.</li></ul>	Operator  Operator  Operator
LED 3 flashes purple and LED 2 lights blue → Backflow alarm from rainwater tank	There is sewage backflow contaminating the rainwater tank.	<ul style="list-style-type: none"><li>▶ Clean the tank.</li></ul>	Operator



## 10.2. Malfunctions of entire system

Malfunctions of entire system	Possible causes	Measures & Actions	Responsible
→ Water spilled at the DN 50 emergency overflow	The float valve has been contaminated during pipe installation.	<ul style="list-style-type: none"><li>▶ Set the RM3 Controller / rocker switch to [O].</li><li>▶ Open a point-of-use valve and allow the pump to run for about a minute in an attempt to flush the valve clean.</li><li>▶ Then, set the RM3 controller back to the desired operating mode.</li></ul>	Operator
	The float of the float valve rubs against the tank wall.	<ul style="list-style-type: none"><li>▶ Align the float valve in a centre position. To do so, ensure that the float valve is properly pressed into the retainer clip. Additional adjustment is not necessary. Ensure that the reinforced hose is free of stress.</li></ul>	Operator
	The valve is obstructed by premature scale build-up due to hard water.	<ul style="list-style-type: none"><li>▶ Run an operational check of the float valve according to Section 9.1.4. In case of early wear, replace the float valve (Section 9.2.1).</li></ul>	Operator
The pump is unable to draw in rainwater.	<p>The suction line or check valve draws air.</p> <p>Excessive friction loss.</p>	<ul style="list-style-type: none"><li>▶ Check the suction line and the check valve for leakage.</li><li>▶ Check the length and height differences according to Section 6.3.3</li><li>▶ Check the suction line and add a feeder pump where necessary.</li></ul>	Operator



Malfunctions of entire system	Possible causes	Measures & Actions	Responsible
<p>The system runs on mains water only.</p> <p>Note: The mains water meter shows a constant flow, or here is make-up noise coming from the float valve.</p>	<p>The float switch in the collecting tank (such as rainwater cistern/underground tank) is installed too deep or incorrectly or is not working.</p>	<ul style="list-style-type: none"> <li>▶ Check the float switch is properly installed. See Sections 6.4.1 and 6.4.2.</li> </ul>	Operator
	<p>There is a short circuit in the cable between the device and the float switch in the collecting tank (e.g. rainwater cistern/underground tank), i.e. the two blank wires are in contact or there is a water inflow at an extension point.</p>	<ul style="list-style-type: none"> <li>▶ Check the cable or check cable extensions for water inflow where necessary.</li> </ul>	Operator
<p>The pump constantly cuts in at short intervals.</p>	<p>The water flow through a point of use is not sufficient, falling below the minimum flow rate of 1 Litre per minute.</p>	<ul style="list-style-type: none"> <li>▶ Check the flow rate at the point of use.</li> </ul>	Operator
	<p>There is a leak on the delivery side, or a point-of-use valve is leaking.</p>	<ul style="list-style-type: none"> <li>▶ Shut off the stop valve on the delivery side of the plant.</li> <li>▶ Check whether the value on the pressure gauge is decreasing and the pump restarting. If this is not the case, the leak is not located in the plant but in the downstream delivery line.</li> </ul>	Operator
<p>There is a drop in pressure although the stop valve on the delivery side is closed.</p>	<p>The check valve in the flow switch is leaking.</p>	<ul style="list-style-type: none"> <li>▶ Replace the flow switch.</li> </ul>	Operator
<p>The pump tries to start, but only hums.</p>	<p>The pump shaft of the pump is blocked.</p>	<ul style="list-style-type: none"> <li>▶ Check the pump shaft. Turn the pump shaft by the fan impeller to unblock the shaft. To do so, you may need a flat-tip screwdriver to place it on the centre of the impeller cover and turn the shaft carefully.</li> </ul>	Operator
<p>The pump shaft of the pump turns easily, but the pump doesn't run.</p>	<p>The starting capacitor of the pump may not be making proper contact.</p>	<ul style="list-style-type: none"> <li>▶ In case of need, replaced the starting capacitor of the pump.</li> </ul>	Fitter / electrician



After correcting the fault, reconnect the plant with a suitable power socket. The power plug of the plant must always be freely accessible and not covered. Reset the plant to the desired operating mode.



## 11. Decommissioning

Follow the following steps to decommission the plant:

- ▶ Set the rocker switch of the controller to [O].
- ▶ Close the shut-off valve of the mains water make-up component.
- ▶ Open a point-of-use valve, such as a toilet flusher.
- ▶ After a short run time of the pump and emptying the mains water tank, the run-dry protection will be activated.
- ▶ Once the pump has stopped operating, pull the power plug.
- ▶ The plant is now out of operation.

For commissioning the plant, proceed as described in Chapter 8 Commissioning.

## 12. Final disposal



The operator of the system must recycle the packaging material in accordance with the local waste management regulations.

---

At the end of life cycle, the equipment shall be shipped, free of freight charge for the manufacturer, to DEHOUST GmbH for disposal. All further dismantling/recycling action will be taken by the manufacturer.



## 13. Declaration of Conformity

# DEHOUST



## EU declaration of conformity

### No. 2025-02

We confirm the conformity to the essential requirements of the European directives:

- ▶ 2006/42/EG Machine Directive
- ▶ 2011/65/EU RoHS Directive
- ▶ 2014/30/EU Directive Electromagnetic Compatibility

The EU declaration of conformity applies to the following units and product designation:

<b>Product group</b>	Rainmanager Dehoust Regenmanager® RM
<b>Model Numbers,</b>	Dehoust Regenmanager® RM3, 812240
<b>Article Numbers</b>	Dehoust Regenmanager® RM5. 815092
<b>Manufacturer</b>	Dehoust GmbH Gutenbergstr. 5-7 69181 Leimen, Germany

The following standards were mainly applied:

- ▶ EN ISO 12100:2010 Safety of machinery – General principles for design – Risk assessment and risk reduction
- ▶ EN 60204-1:2018, ISO IEC 60204-1:2016 Safety of machinery – Electrical equipment of machines – Part 1: General requirements
- ▶ DIN EN 1717:2023 Protection against pollution of potable water in water installations and general requirements of devices to prevent pollution by backflow
- ▶ DIN EN 16941-1:2022 Rainwater harvesting systems for non-potable uses – Part 1: Design, performance and testing

Created by Jürgen Kolb, CE Officer

Leimen, 5<sup>th</sup> of May 2025

---

Place and date of issue



---

**Andreas Bichler**  
CEO

Signed on behalf of: **DEHOUST GmbH**



## 14. Appendix: List of abbreviations and technical terms

Abbreviation	Function
<	less than
>	greater than
®	registered trademark
A	ampere
W x H x D	width x height x depth
BGB	German civil code
cm	centimetre
dB	decibel
DN	nominal diameter (bore size)
Firewall	In computing, the firewall is security technology for separating network areas from one another.
g	metric gram
h	hour
Hz	Hertz
IT	internal (female) thread
kg	metric kilogram (1000 grams)
L	Litre
min	minute
mm	millimeter
N/A	not applicable
nm	nanometre (1 mm = 1,000,000 nm)
Nm	newton meter
OT	Outer or external (male) thread
PE-HD	The improved high-density polyethylene materials (PE-HD) used in today's pipe production are characterized by their high flexibility and durability. PE-HD pipes have a long life cycle and thus a high efficiency in the long run.
PP	polypropylene, a plastic material
PVC	polyvinyl chloride, a plastic material
touch screen	a display screen operated by human touch
V	volts
W	watts

# DEHOUST

ENERGY. HEAT. WATER.

## **DEHOUST GmbH**

### **69181 Leimen**

Gutenbergstr. 5-7

Phone +49 62 24 / 97 02-0

Fax +49 62 24 / 97 02-70

info@dehoust.de

### **31582 Nienburg**

Forstweg 12

Phone +49 50 21 / 97 03-0

Fax +49 50 21 / 97 03-70

### **01809 Heidenau**

Dürerstr. 1

Phone +49 35 29 / 56 58-0

Fax +49 35 29 / 56 58-70

### **53783 Eitorf**

Wecostr. 7-11

Phone +49 22 43 / 92 06-0

Fax +49 22 43 / 92 06-66

[www.dehoust.com](http://www.dehoust.com)

The information in this publication is subject to change. We reserve the right to make technical changes without prior notice. Performance specifications are non-binding; a guaranteed feature cannot be derived from them. The terms and conditions agreed with our order confirmation shall apply exclusively.

The country-specific approvals and installation regulations must be complied with.



[www.dehoust.com](http://www.dehoust.com)